

**A NOVEL APPROACH TO INDUSTRIAL ASSESSMENTS FOR  
IMPROVED ENERGY, WASTE STREAM, PROCESS AND  
RELIABILITY**

SUCCESS by DESIGN

Howard W. Penrose

Old Saybrook, Connecticut

© 1999

## Table of Contents

<b>Executive Summary</b>	<b>i</b>
<b>Chapter 1 Introduction</b>	<b>1</b>
Problems with Modern Industrial Energy Audits	1
Purpose of Computer Simulation in Industrial Energy Audits	3
Importance of Reduced Energy, Waste Stream, and Improved Reliability	5
Reducing Cost Per Unit of Production Approach	6
Thesis Statement	8
Definitions	9
<b>Chapter 2 Review of Related Literature</b>	<b>13</b>
Most Discussed Topics	13
Energy Audits	13
Industrial Assessment Centers	14
US Department of Energy Challenge Programs	15
Air Master Auditing	18
US Department of Energy Steam Challenge	23
Combined Heat and Power Challenge	26
Energy and Waste Stream Calculation Methodologies	29
Replace Drive Belts on Large Motors	29
Using Synthetic Lubricants	32

Monitoring Electrical Demand	32
Turning Off Equipment Not in Use	35
Installing Set Back Timers on Thermostats	36
Periodic Inspection and Adjustment of Boilers	38
Lighting Retrofit	41
Electric Motor Retrofits	45
Variable Frequency Drives	49
Waste Reduction	52
Maintenance and Reliability	54
Human Factors in Reliability and Safety	56
Maintenance System Definitions	58
Incoming Power Considerations	60
Power Factor and Correction	62
Power Connections	68
Voltage Unbalance	70
Motor Starters: Inspection and Maintenance	72
Alternating Current Induction Motor Design	73
Introduction	73
Purpose of Induction Motors	74
Induction Motor Construction	75
Operating Principles	76

Torque	78
NEMA Motor Design Classifications	79
Design E Motor Discussion	80
Electric Motor Insulation	82
Energy Efficient Electric Motors	85
Inverter Duty Motors	87
Variable Frequency Drives	88
Variable Torque Loads	88
Constant Torque Loads	90
Basic Drive System	91
Basic Operation of a PWM Inverter	91
Application Considerations	93
Variable Speed Concerns	93
Power Quality	95
Inverter Duty Failures	96
Troubleshooting Drives	98
Mechanical Systems	99
Bearings	99
Reliability	104
The Reliability Function	106
Failure Rate	107

Reliability Component Relationships	108
Related Factors to Reliability	109
Considerations for Reliability	111
Industrial Systems Engineering	112
Work Measurement	116
Computer Simulation Techniques	121
<b>Chapter 3: Research Methods</b>	<b>129</b>
Project Approach	129
Data Gathering	130
Stage 1: Process Simulation Software	130
Stage 2: Confectionery Company Survey	131
Stage 3: Power Plant Rotating Equipment Survey	131
Stage 4: Bakery Project	132
Stage 5: Grain Miller Survey	133
Data Review	133
Originality and Limitations	133
<b>Chapter 4: Data Review</b>	<b>135</b>
Selection of Process Simulation Software	135
Confectionery Company Industrial Survey	138
Energy Consumption	139

Electric Motor Energy Conservation	140
Steam Trap Opportunities and Improvements	142
Reliability Program Opportunities and Recommendations	147
Power Plant Survey	153
Electric Motor Energy Recommendations	155
Preventive Maintenance Recommendations	162
Predictive Maintenance Recommendations	164
Corrective Maintenance Recommendations	167
Proactive Maintenance Recommendations	170
Spare Equipment Considerations	171
General Comments and Recommendations	173
Commercial / Retail Bakery Assessment	177
Energy Conservation Opportunities	180
Insulate Doors and Windows	180
Boiler Maintenance and Trim	182
Uninsulated Steam and Hot Water Piping	183
Freezer and Compressor Opportunities	184
Packaging Machine Usage	187
Building Heat Loss – Windows and Doors	187
Lighting Retrofit	189

Production and Reliability Improvements	189
Create Master Production Schedule	190
Repair Oven	191
Repair Cookie Cutter	192
Steam Kettles	192
Rearrange Work Stations	193
Impact of Production and Reliability Improvements	193
Waste Stream Opportunities	194
Grain and Corn Miller Survey	196
Electric Motor System Recommendations	198
Compressed Air System Opportunities	200
Packaging Plant Pressure Loss	202
Air Leaks at the Fungi and Cooking Plant	207
Additional Recommendations	209
Steam Opportunities	211
Miller Steam System	211
Steam Trap Opportunities	212
Steam Leak Opportunities	214
Plant-Wide Lighting Retrofit Assessment	216
Miller Waste Stream	216

Waste Water Through Water Hoses on Pumps	217
Excess Steam Recovery	218
Replacing Electric Motors with Additional Steam Turbines	219
Reducing the Amount of Steam Provided to Plant	220
Additional Waste Stream Comments	220
Maintenance and Reliability Observations	221
Vibration Analysis Program	222
Infrared Analysis	223
Pump Seal Failure Analysis	225
Additional Reliability Recommendations	230
<b>Chapter 5: Conclusions</b>	<b>231</b>
<b>Bibliography</b>	<b>236</b>



## **Executive Summary**

Through the performance of a thorough review of industrial energy, waste stream, process, and reliability audits, combined with a review of industrial simulation systems, a complete industrial assessment can be performed. The complete industrial assessment is performed to take advantage of all major opportunities while reviewing their impact on the rest of the industrial system. For instance, if it is determined that a variable frequency drive placed on the production line will save electrical energy, what is its impact on production? Will it improve production and create another bottleneck? Or will it slow production causing the rest of the system to “starve?”

The method outlined in this Dissertation was drafted and performed as part of several projects underway at the University of Illinois at Chicago, Department of Engineering, Energy Resources Center. These projects were: The Illinois Food Processing Survey sponsored by the Illinois Department of Commerce and Community Affairs; A power plant survey sponsored by Dreisilker Electric Motors, Inc.; and, an Industrial Engineering Senior Design Project on the Commercial / Retail Bakery, which won the Abbott Laboratories’ Process Engineering Design Award and the UIC Department of Engineering Process Design Award.

Within each of these studies, various approaches and types of simulation were utilized:

- Within the bakery survey, process simulations utilizing ProModel™ software were used to identify the greatest opportunities in process improvement.
- Within the power plant survey, MotorMaster Plus was used to determine strategies for electric motor systems.
- ASDMaster was used at the confectionery plant to assist in the troubleshooting of the motor-drive root-cause-analysis.
- MotorMaster Plus was again used at the grain and corn miller with strong recommendations for the implementation of a process simulation.

In each case, the impacts of the recommendations were measured and linked. For instance, waste steam (excess steam) from the grain and corn miller could be reused by the process, possibly used to run steam turbines. The results would be: reduced wasted steam, reduced waste natural gas, and reduced energy costs. In all cases, an improvement of greater than 15 percent combined energy, waste, process, and reliability improvements could be realized. The total project cost for three food processing plants was \$60,000 while the power plant survey was

\$5,000. All recommendations were based upon less than five year simple payback, however, most were found to be under two years.

The general outline for such a project is as follows (See Chapter 5 for details):

1. Gather basic information and perform a site visit.
2. Evaluate provided data and determine best approach.
3. Perform data collection.
4. Perform data analysis.
5. Write report and presentation.

It was also found to be very important, and to ensure that the recommendations would be implemented, that the final report be written in simple and plain english. Formulae, numbers, savings, etc. should be reported, however, if the impact is not explained in a straight-forward, simple manner, the reader may not understand the importance of the recommendations.

Through the use of the methods described, each of the projects performed were great successes. These successes were measured as completed on schedule, under budget, and the end-users were willing to implement the recommendations.

## **Chapter 1: Introduction**

### ***Problems with Modern Industrial Energy Audits***

Standard industrial audits have inherent problems. First of all, they are often performed by engineers with limited real experience, or experience in the industry being audited. Secondly, the audit is primarily concerned with reducing energy or waste from the process with limited, or no, concern for the impact on the process, equipment reliability, or product quality. The goal is mainly a dollar value reduction in overall energy costs versus a reduced cost per unit of production or improved corporate competitiveness.

The overall system is often overlooked. The energy engineer will often look for component energy savings, such as energy efficient electric motor retrofits, without an overall understanding of the impact on the system. For instance, the electric motor system consists of six major components (Figure 1):

1. Incoming Power: offers an opportunity of 9% improvement including increased reliability.
2. Electric Motor Controls: offers an opportunity of 43% improvement including process improvements and reliability.
3. Electric Motors: offers an opportunity of 19% improvement including reliability improvements.

4. Couplings: offers an opportunity of 6% improvement including reliability and process improvement.
5. Load: Includes the immediate driven load such as the pump, fan, compressor, etc.
6. Process: combined with load can have an impact of 33%. However, this number can be higher.

**Figure 1: Electric Motor System**

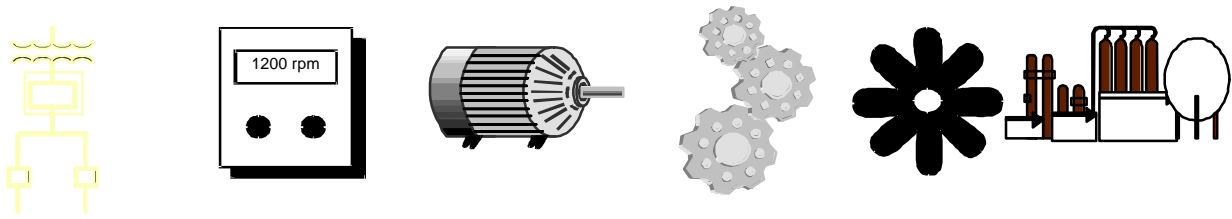

More often than not, an energy auditor will overlook the impact of changes to one part of the system on the rest. For instance, a change from an older U frame electric motor to a new energy efficient motor. The older motor will often have a very different operating speed than the newer energy efficient motor (ie: 1735 vs 1790 RPM, a 55RPM difference). If not properly addressed, this difference in RPM can have adverse effects on system reliability and efficiency as well as product quality.

## ***Purpose of Computer Simulation in Industrial Energy Audits***

The concept of using computer software to assist in industrial audits is not new. For instance, the US Department of Energy, in association with other organizations, has developed a number of software programs for industrial energy and waste stream audits. These include, but are not limited to:

1. MotorMaster Plus: Used to enter electric motor information, including nameplate, electrical, and maintenance information. The user can then run different scenarios for electric motor retrofit, repair versus replace, and electric motor comparison. In addition, the software can be used to assist with the development and maintenance / management of an electric motor system corporate wide. With the advent of version 3.0, the software may be maintained on a network, with security, and contains a database of over 17,500 new electric motors, with list prices. MotorMaster Plus has several flaws, however. These include: a) only allows for three phase induction motor entry, leaving out synchronous, DC, fractional single phase, and other common industrial motor types; b) component level view of only the electric motor portion of the motor system. There are ways around these challenges, but the user loses perspective of the industrial system.
2. ASD Master: Is used to review energy efficient variable frequency drive applications. It includes a multimedia training program which reviews

- Variable Frequency Drive applications, technologies, and problems, and a specification writer program. It does not work compatitively with MotorMaster Plus, but does review the impact of the VFD on other components of the system along with maintenance payback and benefits.
3. Air Master: Reviews the benefits of maintaining the compressed air system along with recommendations to make changes to the system. This includes air leaks, process optimization, etc. Air master does not view the complete system and is actually made up of an Excel for Windows spreadsheet and macros.
  4. FEMP (Federal Energy Management Program) software programs: Include DOE2 and various waste stream programs. Primarily component and commercial level recommendations, with DOE2 providing the most complete commercial simulation of the above listed software.

As far as a component level study of the components of the system, the present energy software plays an important role. However, in an industrial facility several things are of concern:

1. The programs are not focused on the impact on industrial process systems.
2. If viewed, or used, one at a time, without understanding the impact on the industrial systems, as a whole, or an understanding of the legal and safety requirements of the industry, errors can occur. Take, for instance, a recommendation for a meat processor to increase the temperature in a process

area from 50°F to 68°F. This would increase the temperature beyond the USDA temperature requirement and possibly cause contamination of the meat, should the recommendation be followed. Although, the refrigeration costs would be reduced.

3. Reliability of the system.
4. Production levels.

One important simulation software that has been overlooked is process simulation software. This type of software can be used to measure present operation and then implement the changes to be made. The result is the ability to view the overall impact of the system by major, or minor, changes within the system. In addition, this software would also allow for the identification of energy intensive problems, such as bottlenecks, etc.

### ***Importance of Reduced Energy, Waste Stream, and Improved Reliability***

One of the purposes for energy engineers, utilities, and the US Department of Energy, is to determine the best use of energy and reducing waste streams in industrial processes. In some cases, the reliability of system components is reviewed or studied. These areas are important, however, the main purpose of



these audits can, and should, be focused on improving industrial competitiveness by reducing costs. While energy improvements are important, they can only have an impact of an average of 3 to 5% of the total cost to produce a product. Waste Stream is also important and can have a similar effect, depending on the type of process and quality of product.

In some cases, there is a problem with energy and waste stream audits. Not all energy engineers take into account the fact that industrial processes can change on demand. For instance, an auditor may claim to be able to reduce an energy bill by ten percent. However, if the process changes because the industrial facility reduces or increases production, the percentage savings can and will change.

System reliability is also important. A process improvement that takes into account maintenance and reliability, as well as energy and waste stream, can have a significant effect on corporate competitiveness. Through operating cost reduction and the ability to reliably produce product on demand, a corporation can both improve its pricing and profit and increase its customer base.

### ***Reducing Cost Per Unit of Production Approach***

An important aspect to improving industrial competitiveness while improving energy, waste stream, and reliability, is to review the energy cost per

unit of production (\$/Unit). If you are able to reduce this cost, the corporate competitiveness improves through either increased profitability or an increased market share (taking into account customer demand). This can be reinvested and delivered as increased corporate size, reinvestment, and / or increased employment and compensation.

Cost per Unit of Production takes into account materials, energy, production, reliability, and other important expenses. This also allows the view of bottleneck reduction and inventory as an energy and waste stream aspect for the facility. For instance, lighting and air conditioning / heating still operate even though product is held up at a bottleneck. This can be even more important if the product is having an impact on the environment (hot product heating the surrounding air) and in some cases, would have to be reheated or reworked / disposed if held up too long. Other areas can also be found and corrected, such as if materials that do not require heating are heated with materials that do require heating, then the whole batch cooled. The energy to increase then decrease the temperature of the materials that do not need to be heated is wasted, and directly impacts the \$/Unit and the competitiveness of the company. This can only truly be identified through a systems approach which includes industrial engineering and simulation.

## ***Thesis Statement***

The purpose of this study is to develop an overall system for energy, waste stream, and reliability improvement to a complete industrial system. As part of this approach, industrial process simulation utilizing process simulation software will be included to determine the impact of implementing these measures within an industrial system. It is the position of this thesis that energy conservation can be achieved with the benefit of improved industrial competitiveness through a basic paradigm shift. The following issues will be established as interactive with each other:

1. Energy efficient equipment (motors, lighting, etc.)
2. Waste stream improvements (even rework requires additional energy)
3. Reliability and maintenance (keeping equipment running)
4. Product quality
5. Process optimization and simulation (reducing process problems)
6. Inventory control.

The overall objective is to present a system for industrial system energy auditing that improves not only energy use and waste stream, but also improves industrial competitiveness with an overall impact on the US economy.

## **Definitions**

Following are basic definitions used in energy, waste stream, and process improvements for industry. In many cases different terminology represents the same item or action. (Penrose, 1997)

- ❑ *Motor System*: Includes the power distribution system; the motor starting control, and drive system; the motor; the mechanical coupling; the load; and the process.
- ❑ *Motor Systems Management*: Refers to an established plan or program whose goal is to effectively maintain the electric motor system at optimal readiness.
- ❑ *Power Quality*: Optimal power quality is termed as sinusoidal voltage and current operating in unity and 120 electrical degrees in a three phase power system. Any deviation is termed as reduced power quality.
- ❑ *Reduced Power Quality*: Can be shown as non-sinusoidal waveforms which contain harmonics, non-unity power (current lags voltage or vice-versa), phase angle problems, under or over voltage, voltage or current unbalance, and other similar power quality defects.
- ❑ *Motor Control*: A system for starting and controlling electric motor operation. This may include a simple circuit breaker to a complicated variable frequency drive system.

- *Variable Frequency Drive*: Is termed VFD or may also be called an Adjustable Speed Drive (ASD). This equipment is often used for energy savings (variable torque) or production (constant torque). Theory and application will be explored further in this thesis.
- *Electric Motor*: A device for converting electrical energy to mechanical torque. May be operated using three phase alternating current, single phase alternating current, or direct current to operate.
- *Coupling*: A device which transfers the output torque from an electric motor to a load. The two methods of achieving this are either direct drive or pulley/chain and sprocket. For the purposes of this thesis, any system in which the motor shaft is part of or enters directly into the load may be considered direct drive.
- *Load*: The system load may be considered as a compressor, fan, pump, or the like. It is basically the system which takes the mechanical torque and converts it into some other, or different value, of energy.
- *Process*: This is where the energy is used. For example: After a compressor is used to change mechanical torque to pressure, the pressure is transferred through a system to a tool which uses compressed air.
- *Reactive Maintenance*: Is a maintenance method in which the equipment is allowed to operate until it fails, unexpectedly, and is then repaired or replaced.

- *Corrective Maintenance*: The practice of repairing equipment once it has failed.
- *Preventive Maintenance*: A method in which basic maintenance practices are scheduled on a regular basis. The purpose is to extend the life of the equipment as long as possible between failures. Greasing and megger tests fit into this category.
- *Predictive Maintenance*: A method in which corrective maintenance is determined and scheduled before catastrophic failure as determined by a series of measurable and repeatable tests. Vibrations Analysis and Thermography Programs fit into this category.
- *Proactive Maintenance*: The action of utilizing information gathered through all maintenance and management actions to alter maintenance, management, and other processes to increase equipment life. This may include capturing repeated long term failures due to correctable outside forces and correcting those forces.
- *Human Factors*: Human and personnel capabilities play a large part in motor systems management. Through proper implementation of a Total Motor System Management Program the stresses involved in maintaining and managing motor systems will be reduced creating an alert maintenance crew who can better perform Proactive Maintenance versus Reactive Maintenance.

The program also requires Maintenance, Operator, and Management accountability and support for improvements.

- *Computer Simulation*: Software programs for simulating energy savings and process improvements.

## **Chapter 2: Review of Related Literature**

### ***Most Discussed Topics***

The most often discussed topics as related to this dissertation are broken into four distinct subjects:

1. Energy and Waste Stream Audits;
2. Maintenance and Reliability;
3. Process and Industrial Engineering;
4. Computer Simulation.

Each of the above topics are normally handled as separate subjects, and, as such will be handled separately in this Chapter. Areas which relate will be identified in a final sub-chapter entitled – Most Related Topics.

### ***Energy Audits***

Industrial energy conservation and waste stream audits can be fairly straight forward, or complicated, depending on the approach. In either case, numerous benefits can be found with reasonable paybacks. However, most companies do not pursue these audits because of the initial expense in time and money. Companies also perceive energy as only having a minor impact on cost



savings as a whole. When considering energy and waste stream, for the sake of energy and waste stream only, this view can be considered realistic.

### Industrial Assessment Centers

“Energy conservation, waste minimization, pollution prevention and productivity enhancement all represent areas investigated during the industrial assessment. Energy conservation strategy research and development since the oil embargo years has enriched the possibilities of use reduction methodology’s application to the small and medium sized industrial manufacturer.” (Rutgers, 1996, p. 1-3)

The US Department of Energy Office of Industrial Technologies developed a program which uses 30 Universities nation-wide known as Industrial Assessment Centers. The purpose of these centers is to provide no cost complete industrial assessments for manufacturers which meet the following criteria:

- ❑ Within Standard Industrial Codes (SIC) 20-39
- ❑ Within 150 miles of a host campus
- ❑ Gross annual sales below \$75 Million
- ❑ Fewer than 500 employees at the plant site
- ❑ Annual energy bills more than \$75,000 and less than \$1.75 million
- ❑ No professional in-house staff to perform the assessment.

The IAC's perform industrial assessments, which are defined as an in-depth assessment of the plant site including its facilities, services, and manufacturing operations. The teams consist of students and faculty who enter plants and take data and measurements. Once complete, a report is drafted and provided to the company. Data, results, and recommendations are provided on a database to provide ideas and concepts to others. The audit, however, incurs no obligation to implement any of the recommendations.

#### US Department of Energy Challenge Programs

The US Department of Energy has also implemented a number of "Challenge" programs including:

- ❑ Motor Challenge
- ❑ Steam Challenge
- ❑ Air Challenge
- ❑ Process Heat Challenge

Motor Challenge, initially, just focused on the electric motor as a potential energy opportunity. Later, the program began focusing on the motor system, then

on motor system maintenance and management. Workshops, materials, and software were developed to support the program.

The US DOE Motor Challenge Energy Management Program “is designed to assist the industrial facility engineer to reduce energy costs through:

- Identifying and analyzing motor driven system energy conservation opportunities.
- Troubleshooting and tuning the in-plant electrical distribution system.
- Correcting power factor.
- Understanding utility billing statements, and
- Establishing a preventive and predictive maintenance program.

Why should industrial plant staff work to save energy? One answer is money. Ever-increasing utility costs reduce profits, erode capital and maintenance budgets, increase product costs, and reduce competitiveness.” (US Department of Energy, 1996, p. 1-1)

*A common misconception within industry has been to equate an energy reduction or conservation program with the concept of turning off equipment and shutting down processes. Instead, the program of energy management challenges plant staff to produce the products or services with the absolute minimum energy consumption. The objective is to minimize energy usage through production efficiency gains, while procuring the lowest cost and most reliable supplies of fuel and power.*

*In addition to reduced energy costs and potentially increased profits, industries that take advantage of energy efficiency opportunities often gain additional benefits such as:*

- ❑ *More productive state of the art technology that improves a facility's competitive edge and improves global competitiveness;*
- ❑ *Improved environmental performance and compliance with environmental and pollution abatement regulations; and*
- ❑ *An enhanced public image as an environmentally friendly or "green" company.*

*Energy management is not a one-person responsibility or a one-time investment in conservation measures. Energy management is an ongoing effort marked by gradual improvements in energy efficiency. A successful energy management process is marked by:*

- ❑ *Maximizing production efficiency;*
- ❑ *Minimizing energy consumption;*
- ❑ *Maintaining a high energy load factor;*
- ❑ *Correcting for low power factor; and*
- ❑ *Acquiring and using economical supplies of energy.*

*Energy management does not just happen. Effective energy management occurs when the idea and practices associated with energy management become part of the "corporate culture." (US Department of Energy, 1996, p. 1-1)*

In addition, the US Department of Energy has provided MotorMaster Plus motor management software. MM+ is primarily an electric motor efficiency and payback software. This software allows the user to make electric motor retrofit or repair-vs-replace decisions by entering basic nameplate information. In version 3.0 (1999), the user is able to enter company data, electric motor inventory, utility rates, basic maintenance data, predictive maintenance data, and other information. Energy improvements may be determined through batch analysis of all the motors in inventory and tracked by energy consumption per unit of production. This software will be discussed in more depth later in this dissertation. (Penrose, 1997, pp. 4 and 5)

Other programs include Air Challenge. Unlike a Motor Challenge audit, which requires only electric motor and related data for analysis, an Air Master audit requires more thought and preliminary work.

### Air Master Auditing

An Air Master Compressed Air Systems audit software and materials is “to provide tools and procedures for performing audits of compressed air systems used in industrial plants, the Bonneville Power Administration developed AirMaster. The software and supporting manuals are designed for general auditors or plant personnel to use while evaluating compressed air system

operation with simple instrumentation during a short term audit. AIRMaster focuses on Operations and Maintenance (O&M) measures because these measures typically entail low capital costs, quick paybacks and low technical risks or risks to production.” (BPA, 1997, p. 1)

“AIRMaster can model part load system operation with up to five rotary screw and reciprocating compressors operating simultaneously, along with varying control strategies and operating schedules. AIRMaster lets auditors simulate existing and modified system operation, and evaluate savings from straight-forward O&M measures with short payback periods. AIRMaster can be used to evaluate the following [Energy Efficiency Measures]:

- ❑ Reduce plant air leaks
- ❑ Adjust manual staging
- ❑ Use unloading controls
- ❑ Reduce system pressure
- ❑ Sequence compressors
- ❑ Reduce run time” (BPA, 1997, p. 1)

A recommended Air Audit report consists of eight sections made up of:

- ❑ *Executive Summary:* Project purpose, description, and key recommendations.
- ❑ *Project Methodology:* Plant selection, analysis and data collection methods, and overview of Energy Efficiency Measures (EEMs) considered.
- ❑ *Plant Summary:* Overview of the plant.

- *Summary and Conclusions:* Conclusion from audit findings and compressed air systems.
- *Recommendation:* Tips for improving compressed air system operation.

The audit procedure is as follows (BPA, 1997, pp. 5-6):

- **Pre-Audit:** Power is to be monitored by the participating utility for approximately two weeks. Power data, electric bills and electricity rate schedules were collected before the audit date. Each audit is to be preceded with an interview with plant personnel. General compressed air system components and specifications were discussed and recorded. This step is followed by a plant walk-through, at which time key components of the compressed air system were identified.
- **Power Measurement:** BPA provides an Audit Manual which outlines several methods to measure hourly loads and power for performance points. For each audit, power is measured with a three-phase power meter. Hourly loads for system operating profiles is to be measured as compressor power and recorded using dataloggers with three-phase power meters.
- **Air flow measurements:** can be taken and entered where cost effective.
- **Pressure measurement:** End use and performance point pressures should be measured with a pressure gauge and a quick release hose fitting. Otherwise, system pressure gauges may be used.

- Leak detection: An ultrasonic leak detector may be used to detect compressed air leaks. This should be done during non-production periods as leaks are easier to detect because noise levels are lower and detection while equipment is off is safer.

Following are the general EEM's for compressed air systems. (BPA, 1997, pp. 6 and 7):

- Reduce plant air leaks: Determine proposed system air flow profiles based on proposed leak air flow and fixed air flow adjustments. Compressed air is very inefficient with as much as 95% of compressor power being dissipated as heat. Therefore, leaks can be expensive. Monitor compressor loads during various operating conditions to estimate how much compressed air is lost to leaks, and how much these leaks cost. Air flow is reduced by repairing compressed air leaks throughout the plant and by making fixed air flow measurements, e.g. by eliminating "planned leaks." A planned leak is a very inefficient use, e.g. using compressed air for cooling or cleaning, and analytically treated the same as other, unplanned, leaks.
- Adjust manual staging (no sequencer): Adjust proportional pressure ranges on modulating only compressors to alter compressor staging. Compressors are staged according to full load pressures and pressure ranges. Staging may be changed by altering the full load pressures and pressure ranges. Staging may



be changed by altering the full load pressures of available compressors. In some cases the fixed pressure ranges also are altered. System efficiency can be improved by staging compressors to minimize the energy required to deliver a required air flow. In many cases, two compressors operating at part load will be staged so that one compressor operates at full load while the other is at part load or is turned off, resulting in lower energy use.

- Use unloading controls: Install or adjust existing unloading controls with optional automatic shutdown timers. Compressors are most efficient when operating at capacity. Efficiency decreases with air flow modulation, and power use remains high because compressors must work against system pressure, even when no air is delivered. Unloading controls reduce no-load power by allowing the compressor to discharge some of its pressure. System efficiency can be improved by adding unloading controls or adjusting existing controls to unload at the highest point possible.
- Reduce System Pressure: reduce average system pressure by a specified amount. Reducing system pressure will reduce the pressure difference across each system compressor, thereby reducing compressor power. The amount of pressure reduction depends on system requirements and current operating pressures. Air supplied to end uses and leaks will also decrease at lower pressure, resulting in additional efficiency improvements which were not accounted for.

- Sequencing compressors: Compressors are sequenced using unloading controls or by installing an automatic sequencer. Sequencing applies to systems with multiple compressors that have existing or proposed unloading controls or an automatic sequencer. The unloading of compressors without an automatic sequencer depends on pressure range settings to determine which compressor is in lead position, which is in second, and so forth. These settings typically are not adjusted routinely. An automatic sequencer allows for more complicated sequencing. System efficiency can be improved by sequencing compressors so that the optimum, often minimum, number of compressors operate to satisfy each air requirement.
- Reduce run time: Turn off compressors that are not needed. Compressors operating at part load use between 16% and 100% of full load power depending on load, compressor type, model, and control type. Shutting off compressors that are not needed will save energy.

US Department of Energy Steam Challenge (US DOE, 1998)

*Steam Challenge is a voluntary program that provides information and technical assistance to companies who have questions about their steam systems and are interested in pursuing opportunities to increase steam system efficiency.*

*Steam Challenge is dedicated to:*

- *Improve industrial competitiveness through enhanced productivity and lower production costs.*
- *Provide steam plant operators with the tools and technical assistance they need to improve the efficiency of their steam plants, and*
- *Promote greater awareness of the energy and environmental benefits of efficient steam systems through improved technology and operation.*

*By offering a variety of tools and services the Steam Challenge program seeks to help companies identify and implement projects that will help enhance safety, save money, improve productivity, and lower emissions. Steam Challenge Tools and services include:*

**TABLE 1: Steam Challenge Offerings**

<b><i>Tools</i></b>	<b><i>Services</i></b>
<i>Fact sheets</i>	<i>Demonstrations</i>
<i>Brochures</i>	<i>Seminars</i>
<i>Checklists</i>	<i>Training</i>
<i>Guidebooks</i>	<i>Workshops</i>
<i>Software</i>	<i>Conferences</i>
<i>Case Studies</i>	<i>Access to Steam Efficiency Experts</i>

*For industrial steam system owners and operators, Steam Challenge is a voluntary program that can provide access to targeted information on steam system efficiency. Suppliers of steam related technologies have the Steam Team which enables providers of steam products and services to provide input into the program and work together to provide “total steam system efficiency.” The US DOE, the Alliance to Save Energy, and a technical advisory committee reviews all material before recommending it for use by industry.*

Steam Challenge is an important aspect to the potential savings of process industries. “In 1995, US manufacturers consumed roughly 16.55 quadrillion Btu (quads) of energy for heat, power, and electricity generation. According to the Council of Industrial Boiler Owners, approximately two-thirds of all the fuel burned by these companies is consumed to raise steam, representing approximately 9.34 quadrillion Btu of the 1995 energy total.” (US DOE, 1998) There are over 54,000 large boilers used by manufacturers to provide steam for industrial systems. Approximately \$21 billion per year is spent by industry to fuel these boilers with total demand for steam projected to increase 20 percent in five major industries (Chemicals, Foods, Refinery, Paper, and Primary Metals) by 2015, with demand in Food Processing (SIC 20) and Chemicals representing the greatest increase.

The US Department of Energy has identified seven industries which are identified by the US DOE’s Office of Industrial Technologies as “Industries of the

Future.” These industries are identified as those with the most energy and waste intensive processes amongst manufacturers. On a weighted average basis, approximately 45 percent of their total energy consumption was used to raise steam. The proportion of total energy for steam was especially high in forest products, chemicals, petroleum refining, and steel. These industries overlap with the most steam intensive industries, which include chemicals, pulp and paper, food and kindred products, and petroleum refining.

#### Combined Heat and Power Challenge (US DOE, 1998)

Combined Heat and Power systems, otherwise known as Cogeneration Systems, generate electrical and / or mechanical energy along with thermal energy. The primary purpose of this equipment is to provide electrical or mechanical energy with a by-product of thermal energy which is captured and used to generate steam for heating, cooling, or process. On-site generation reduces transmission and distribution losses.

The inherent efficiency of CHP systems translate into energy cost savings for the consumer and significant reductions in pollutant emissions compared with separate centralized generation of electrical/mechanical and thermal energy. CHP represents strategies for energy consumers and states to meet environmental goals while reducing operating costs. This results in:

- ❑ A cleaner environment
- ❑ More competitive companies and economic growth
- ❑ Increased job security, and
- ❑ More efficient use of energy resources

CHP systems are now used extensively by several of the economy's most energy-intensive industries, including pulp and paper, chemicals, and petroleum refining. Several recent developments have renewed interests of both government and industry in expanding CHP applications in other industries as well as other sectors of the economy:

- ❑ Recent advances in technologies such as combustion engines, steam turbines, reciprocating engines, fuel cells, and heat recovery equipment have decreased the cost and improved the performance of CHP systems.
- ❑ A significant fraction of the nation's boilers will need to be replaced in the next decade, which creates a window of opportunity to upgrade this equipment with clean and efficient CHP systems.
- ❑ Environmental policies including the need to address concerns about greenhouse gas emissions, have created pressures to find cleaner and more efficient means of using energy.

- The restructuring of markets for electric power are creating new opportunities for innovations in power generation and smaller-scale distributed systems such as CHP.

Although the technical performance and affordability of CHP systems have greatly improved, significant barriers limit widespread use of CHP in the United States. These barriers influence investments in capital equipment, and tend to lock-in continued use of less-efficient infrastructure of electricity generation equipment. The main barriers to CHP include the following:

- Environmental Policies – Environmental permitting for CHP systems is complex, costly, time-consuming, and confusing. Air pollution permits are required from state environmental authorities before plant construction can begin. Current environmental regulations do not recognize the overall energy efficiency of CHP, or credit the emissions avoided from displaced electricity generation.
- Utility Policies – Many utilities currently charge backup rates and require complex interconnection arrangements for CHP systems. Increasingly, policies for the recovery of “stranded costs” in electricity restructuring include “exit” and/or “transition” fees to customers who build CHP facilities.
- Tax Policies – Depreciation schedules for CHP investments vary depending on system ownership. The depreciation period can be as long as 39 years for

some types of owners, far longer than the depreciation period for utility-owned power plants. Also, the varying depreciation period limits the use of alternative financing or ownership arrangements.

The US Department of Energy seeks to open a national dialogue on CHP technologies to raise awareness of the energy, environmental, and economic benefits of CHP, and promote innovative thinking about ways to accelerate the use of CHP. Key participants in this challenge will be state and regional officials. Grants are being provided as are workshops and outreach programs.

#### Energy and Waste Stream Calculation Methodologies

In this sub-chapter, we shall explore different calculations and methods of approach for improving energy and waste stream based upon common approaches.

*Replace Drive Belts on Large Motors (Rutgers, 1996, pp. 26-28)*

Most belt driven equipment uses standard V-belts transmit power resulting in an unnecessary loss of energy. “In addition to internal inefficiencies in electric motors, which cause energy loss, the power available at the drive shaft of the



motor cannot be transmitted to a machine through a belt without some additional energy losses. These losses come in the form of slippage, energy used to flex the belt as it goes around the pulleys, and stretching and compression of the belt. A recent study has shown that standard V-belts have a maximum efficiency of 94%. This means 94% of the energy transferred to the drive shaft of the electric motor is transferred to the machinery performing the useful industrial task. There are two readily available means to reduce the losses. One is to replace the belts with energy efficient cog belts. These belts slip less and can bend more easily than standard V-belts. The other method is to use belts with teeth and also replace the pulleys with ones that have sprocketed grooves (essentially installing a timing chain) which is referred to in the industry as a high torque drive belt. In both cases, the belt can bend with less loss of energy and need not be stretched as tightly as the standard V-belt which in turn prolongs belt life. The cog belts also reduce slippage and the HTD's eliminate it." (Rutgers, 1996, p. 26)

The potential energy savings for either belt can be figured using the following formulae (Eq1, Eq2, Eq3, and Eq4), assuming a 2% improvement for cog belts and a 6% improvement for HTD's:

Eq1: Reduction in Electrical Power (kW)

$$PS = (HP/n) \times LF \times S$$

Where: PS = the anticipated reduction in electric power (kW); HP = total horsepower; n = motor efficiency; LF = average load factor; S = estimated energy savings (2% for cog belts and 6% for HTD's)

Eq2: Anticipated Energy Savings (kWh / yr)

$$ES = PS \times H$$

Where H = annual operating time and ES = anticipated energy savings

Eq3: Annual Cost Savings (\$)

$$ACS = (ES \times (\$/kWh)) + ((\$/kW-month) \times PS \times 12 \text{ months} / \text{yr})$$

Eq4: Simple Payback (years)

$$SP = \text{Implementation Cost} / ACS$$

Although HTD's offer a much higher savings and faster payback, most systems that use belts involve high inertia. In these systems, such as fans, pumps, and compressors, slip is required during startup for safety and component life requirements. Therefore, HTD's should not be used in these systems. In

industrial systems which require precision, such as certain conveyor systems, in conjunction with variable frequency drives, an HTD may be more appropriate.

*Using Synthetic Lubricants (Rutgers, 1996, pp. 29-30)*

“Manufacturers of synthetic lubricants claim from actual field experience an energy savings of 10 to 20 percent of the energy normally lost in the operation of electric motors, gearboxes, etc. with the use of their products. These claims are based on information showing that synthetic oils, which run at relatively constant viscosity over an extended temperature range, possess better lubricating properties and are more resistant to oxidation than petroleum based lubricants.” (Rutgers, 1996, p. 29)

The potential savings can be calculated using Eq1 through Eq4, with the average increase in efficiency of 10%. The implementation costs are minimal, being primarily set with the costs of the synthetic lubricants which cost slightly more than petroleum lubricants.

*Monitoring Electrical Demand (Rutgers, 1996, pp. 31-33)*

“Power companies charge their customers for the peak kW demand during each month. This is done to encourage their customers to reduce the power spikes

in their operations. By law, power companies must maintain a ‘spinning reserve’ to account for spikes in user demand. However, it is costly for the power companies to maintain these reserves at high levels. The power companies customarily measure demand in the plant by measuring the consumption of electric power over consecutive 15 or 30 minute intervals throughout the month. The peak demand is then selected as that interval with the largest kWh consumption and converted to a kW rate. The power company will then charge a substantial amount of money per kW for on peak demand. (Rutgers, 1996, p. 31)

“Peaks in demand are caused by a number of different factors. The two most important of these are the starting of large motors and the starting of many motors of any size in a single 15 minute period. Electric motors can draw between [4 to 8] times their full load currents during startup. These current spikes will last until the motor has reached nearly full load operating speed [for Design B motors]. For fully loaded motors this is typically between 30 seconds and 2 minutes. The demand spike due to starting a fully loaded motor is approximated by the following equation:” (Rutgers, 1996, p. 32) (Eq5)

Eq5: Demand Spike for Motors

$$DS = ((N \times f \times \Delta T) + (N \times Tr)) / T$$

Where DS = Demand Spike in kW; N = size of motor in kW;  $f$  = increase in current during startup (average of 6 times);  $\Delta T$  = Time that increased current is drawn (average 1.5 minutes); Time period over which the power company measures demand (15 or 30 minute intervals); Tr = time remaining in the measurement period (T -  $\Delta T$ )

The demand spikes from motors can be reduced in a number of ways. These ways include equipment sequencers, such as on chillers, variable frequency drives, and soft starts. The objective is to reduce the overall demand from startup of these systems which, on average, can improve demand by 15% in most larger plants (conservatively). The potential savings can be calculated with Eq6 and Eq7:

Eq6: Anticipated Savings

$$0.15 \times (\text{demand charge}) \times DS = \$/\text{month}$$

Eq7: Annual Savings

$$\$/\text{month} \times (12 \text{ months}/\text{yr}) = \$/\text{year}$$

The machinery which creates the greatest demand spikes can be monitored through the use of a demand meter. If possible, printouts should be obtained from the utility through these meters. Combined with a schedule of equipment operation, the energy manager can identify the opportunities.

#### *Turning Off Equipment not in Use*

Each electric motor, or other energy consuming device, left on while not in use increases demand and energy use, therefore, a policy of turning off equipment when not in use is a simple payback. “Demand spikes will have to be avoided on restarting as mentioned previously, but the consumption costs can be reduced. This can be done by instructing plant maintenance personnel to check all equipment at the beginning of breaks and throughout the day to make sure that they are not running without due purpose.” (Rutgers, 1996, p. 34)

The energy savings realized by shutting off electric motors when not in use can be found by:

Eq8: Anticipated Savings

$$ES = ((HP \times CV) / n) \times HR \times IL$$

Where ES = realized energy savings (kWh / yr); HP = horsepower of motors left on; CV = the conversion factor of 0.746 kW/HP; n = efficiency of motor; HR = the annual hours of unnecessary idling per year; IL = idle load horsepower consumption of motor (10%).

The implementation of this type of energy savings has an immediate payback as it does not cost anything to implement.

*Installing Set Back Timers on Thermostats Controlling Space Heating*

Through the purchase of seven day set back timers to lower thermostat settings in plant during nights and weekends (for heating) a substantial payback may be achieved. An estimate of the savings which can be realized through the installation of setback timers can be made by using the following approach:

Eq9: Percentage of Time Plant not Operating

$$\Phi = ((168 - OT) \text{hrs not operating/wk} / 168 \text{ hrs/wk}) \times (100\%)$$

Where  $\Phi$  = percent of time not operating and OT = operating hours

Eq10: Average Temperature Difference Between the Plant and Outdoors During  
the Winter Months

$$DT = T_p - (65 - (DDY / HD))$$

Where  $\Delta T$  = the average temperature difference;  $T_p$  = the temperature maintained  
in the plant; DDY = the heating degree days for the year for the plant location;  
HD = the number of days per year that the average temperature drops  
significantly below 65°F.

Eq11: Energy Savings in Units Consumed

$$ES = (RT / DT) \times \Phi \times YU$$

Where ES = energy savings in units consumed; RT = reduction in temperature  
during the off hours; YU = the yearly usage for heating.

“The portion of the natural gas for heating may be approximated by  
assuming that the amount used in the production process remains nearly constant  
throughout the year and is the same as can be found by averaging the amount of  
natural gas consumed in the months from May through September. If the natural  
gas bills yield an average of 3,190 therms for those months. The annual use of  
natural gas in production is then:” (Rutgers, 1996, p. 37)



Eq12: Natural Gas Production Use

$$12 \text{ months/yr} \times \text{therms} / \text{month} = \text{therms} / \text{year}$$

$$\text{e.g.: } 12 \text{ mo./yr} \times 3,190 \text{ therms/mo.} = 38,280 \text{ therms} / \text{yr}$$

Eq13: Natural Gas for Heating (YU)

$$\text{YU} = \text{Total Therms/yr} - \text{Production Therms} / \text{yr}$$

For example: Company uses 56,787 therms / year of natural gas and 10,339 gallons / year of heating oil:

$$\Phi = ((168 - 40) / 168) \times 100\% = 76\%$$

$$\Delta T = 70 - (65 - (5674/190)) = 35^\circ\text{F}$$

$$12 \text{ mo./yr} \times 3190 \text{ therms} / \text{mo.} = 38,280 \text{ therms} / \text{yr}$$

$$\text{YU} = 56,787 \text{ therms/yr} - 38,280 \text{ therms/yr} = 18,507 \text{ therms/yr}$$

$$\text{ES (natgas)} = (15^\circ\text{F}/35^\circ\text{F}) \times .76 \times 18,507 \text{ therms/yr} = 6,028 \text{ therms/yr}$$

$$\text{ES(fueloil)} = (15^\circ\text{F}/35^\circ\text{F}) \times .76 \times 10,339 \text{ gal/yr} = 3,368 \text{ gal/yr}$$

$$\text{Savings} = (\$.644/\text{therm} \times 6,028 \text{ therms/yr}) + (\$1.03/\text{gal} \times 3,368 \text{ gal/yr}) = \$7,351/\text{yr}$$

*Implement Periodic Inspection and Adjustment of Combustion in a Natural Gas Fired Boiler (Rutgers, 1996, p. 39)*

“Many factors including environmental considerations, cleanliness, quality of fuel, etc. contribute to the efficient combustion of fuels in boilers. It is therefore necessary to carefully monitor the performance of boilers and tune the air/fuel ratio quite often. Best performance is obtained by the installation of an automatic oxygen trim system which will automatically adjust the combustion to changing conditions. Condition of boiler trim can be determined using a flue gas analyzer.” (Rutgers, 1996, 39)

The optimum amount of oxygen in the flue gas of a gas fired boiler is 2%, which corresponds to 10% excess air. Total savings can be estimated:

Eq14: Savings in Fuel (therms/yr)

$$\text{Therms/yr savings} = (\% \text{ burned in boilers}) \times (\text{annual therms/yr}) \times (\% \text{ possible fuel savings})$$

Eq15: Cost Savings (\$/yr)

$$\$/\text{yr} = (\text{therms saved/yr}) \times (\$/\text{therm})$$

Boiler efficiency tips (Rutgers, 1996, p. 43):

- *Conduct a boiler flue gas analysis once a week, unless an automatic system is operating the controls. Recommended percentages of oxygen, carbon dioxide, and excess air in the exhaust gases are:*

Table 2: Recommended Gas Percentages

Fuel	Oxygen	Carbon Dioxide	Excess Air
Natural Gas	2	0	10
Liquid Petroleum	4	2.5	20
Coal	4	5	25
Wood	5	5.5	30

*The air-fuel ratio should be adjusted to the recommended optimum value.*

*However, a boiler with a wide operating range may require a control system to adjust the air-fuel ration continuously, in order to maintain efficient combustion.*

- *A high flue gas temperature may reflect the existence of deposits and fouling on the fire and water side of the boiler. The resulting loss in boiler efficiency can be approximated by estimating that 1% efficiency loss occurs with every 40°F increase in stack temperature from these conditions. It is suggested that the stack gas temperature be recorded immediately after boiler servicing and that this value be used as the preferred reading. Stack gas temperature readings should be taken on a regular basis and compared with the established reading at the same firing rate. A major variation in the stack gas temperature indicates a drop in efficiency and the need for either air-fuel ratio adjustment or boiler tube cleaning. In the absence of any reference*

*temperature, it is normally expected that the stack temperature will be about 150°F and 200°F above the saturated steam temperature at a high firing rate in a saturated steam boiler (not applicable to a boiler with an economizer and air preheater).*

- *After an overhaul of the boiler, start up the boiler and re-examine the tubes for cleanliness after thirty days of operation. The accumulated amount of dirt will establish the necessary frequency of the boiler tube cleaning.*
- *Check the burner head and orifice once a week and clean if necessary.*
- *Check all controls frequently and keep them clean and dry.*
- *For water tube boilers burning coal or oil, blow out the soot once a day. The Bureau of Standards indicates that 8 days of operation can result in an efficiency reduction of 8%, caused solely by sooting of the boiler tubes.*
- *For frequency and amount of blowdown depends upon the amount and condition of the feed water. Check the operation of the blowdown system and make sure that excessive blowdown does not occur.*

#### *Replacing Standard Fluorescent Lighting with Energy Efficient Tubes*

“Many lighting systems that represented good practice several years ago are inefficient in view of today’s higher electrical costs. A lighting conservation program not only saves energy but is also a highly visible indication of

management's interest in conserving energy in general. The importance of lighting conservation, therefore, should be considered not only for its dollar value savings but also for its psychological effect on the plant's entire conservation program." (Rutgers, 1996, p. 4-29)

A good lighting system program includes setting a lighting standard. One of the first requirements is to set lighting levels in Footcandles (Attachment 1). These levels represent the minimum lighting necessary to perform certain tasks. Once levels have been selected, a light meter audit can be performed in order to determine the existing lighting levels.

Several methods can be performed to reduce costs:

- Turning off lights – “The most obvious and beneficial step to conserve energy is to turn off lights when they are not needed. This approach often requires an extensive publicity program to enlist the support of all employees. First-line supervisors must understand that conserving light is as much a part of their job responsibility as improving productivity. An effective way for members of management to show support for energy conservation is to turn off lights in their own offices when unoccupied. Fluorescent lamps are commonly left on over noon hours or other short periods because of the belief that frequent starts will shorten tube life. This problem is substantially reduced now with tubes that are more tolerant of starts and the increased cost of energy compared with the tube cost.” (Rutgers, 1996, p. 4-33) Fluorescent lamps

should be turned off if the space will be unoccupied for 15 minutes, or more; incandescent lamps whenever the space will be unoccupied; and for high-density discharge (HID) lamps, it is not practical unless the space will be unoccupied for over 30 minutes.

- Automatic Controllers – Use presence detectors that detect when the room is occupied and turns off lights automatically. Or, controllers can be installed that will turn off groups of lights at certain times of the day.
- De-Lamping – “Another direct method to reduce lighting is to simply remove lamps from service where less light is needed. This approach frequently applies to offices or areas in which uniform lighting has been provided. For example, if the fixture is located over an office doorway, lamps can often be removed without reducing the illumination at the desktop. Office lighting loads can frequently be reduced 25% by this arrangement.” (Rutgers, 1996, p. 4-34)
- Maintain lamps – “Dirt and dust accumulations on the fixtures greatly reduces lamp efficiencies. Light intensity can depreciate up to 30% by the time lamps are replaced; in extremely dirty conditions, depreciation can be higher. A minimal cleaning schedule for an average industrial environment is to clean fixtures when the lamps are replaced. The number of lamps required to provide the desired illumination level will depend on the plant’s maintenance

program. Initially, additional lighting will offset the gradual depreciation of light caused by dirt must be provided.” (Rutgers, 1996, p. 4-34)

- Lower Wattage Fluorescent Lamps and Ballasts – In many cases, reducing lighting levels through de-lamping can leave spotty areas of illumination. An alternate method is to install lower wattage (energy efficient) lights and ballasts. Higher efficient systems will often offer the same, or close, candle power while reducing the overall wattage.
- Fluorescent Retrofit Reflectors – The purpose of the reflectors is to increase lighting to the appropriate areas by directing the light to those areas. The result may also be that some lighting (de-lamping) may be pursued as a result.
- Lamp Relocation – Through an emphasis on providing lighting specific to the area where it is required, lighting may be reduced in low traffic or unnecessary areas. Most original lighting systems were designed to provide uniform lighting, which is unnecessary.
- Lighting System Replacement – “Existing incandescent or mercury lighting systems are usually candidates for replacement. Incandescent lighting is suitable for certain applications, but its low efficiency makes it uneconomical for general illumination. A rapid payback can almost always be shown for replacing mercury with more efficient light sources, and especially with high pressure sodium.” (Rutgers, 1996, p. 4-39)

## *Electric Motors – Retrofits*

Electric motors represent a very large opportunity for industry. Throughout the United States, electric motors account for over 20% of all energy consumed, 57% of all electrical energy generated, and over 70% of all electrical energy consumed within an industrial facility, with over 90% in process industries (ie: pipelines, etc.). Electric motor retrofits and repair versus replace decisions can improve electrical energy use by the motor system up to 19%.

*Efficient use of energy enables commercial and industrial facilities to minimize production costs, increase profits, and stay competitive. The majority of electrical energy consumed in most industrial facilities is used to run electric motors. Energy efficient motors now available are typically from 2 to 6 percent more efficient than their standard motor counterparts. This efficiency improvement translates into substantial energy and dollar savings. For instance, a recent study of Northwest industrial sector energy conservation measures revealed a potential for 52.7 Mwa of energy savings replacing standard motors with high-efficiency motors. This savings is annually valued at \$13.8 million given an electrical rate of only \$0.03/kWh.*

*The price premium for an energy efficient motor is typically 15 to 30 percent above the cost of a standard motor. Over a typical ten year operating life, a motor can easily consume electricity valued over 57 times its initial*



*purchase price. This means that when you spend \$1,600 to purchase a motor, you are obligating yourself to purchase over \$92,000 worth of energy to operate it. A price premium of \$400 is negligible compared to saving 3% of \$92,000 or \$2,760. Purchasing new or replacement energy efficient motors makes good economic sense.*

*The efficiency gains associated with energy efficient motors are obtained through the use of refined design, better materials, and improved construction. Many motor manufacturers offer an extended warranty for their premium-efficiency motor lines. Yet less than half of motor sales nationwide are of high-efficiency units. Because of our low-cost electricity, this percentage is undoubtedly even lower in the Northwest region.*

*Durable and reliable energy efficient motors can be extremely cost effective with simple paybacks on investment of less than two years with simple paybacks on investment of less than two years – even in the Northwest. Energy efficient motors should be considered in the following instances:*

- For new facilities or when modifications are made to existing installations or processes*
- When procuring equipment packages*
- Instead of rewinding failed standard efficiency motors*
- To replace oversized and underloaded motors*
- As part of an energy management or preventive maintenance program*

- *When utility rebates are offered that make high-efficiency motor retrofits even more cost effective. (US Department of Energy, 1996, p. v)*

Payback scenarios for energy efficient motor retrofits and repair versus replace can be fairly straight forward. With motor retrofits, you must consider the labor required for the retrofit; any associated costs, such as base and coupling changes; and the full cost of the replacement motor. For a rewind versus replace, you only have to consider the additional parts and the difference between the new energy efficient cost and the rewind costs. In addition, you must reduce the efficiency of the motor to be rewound one to two percent per rewind (ie: an 88% efficient motor that had been rewound twice in the past would be 86% efficient).

The basic payback formulae are:

Eq16: kW Savings

$$KW_{saved} = hp \times L \times 0.746 \times ((100/E_{std}) - (100/E_{he}))$$

Where hp = motor horsepower; L = motor load; E<sub>std</sub> = standard or rewind efficiency; E<sub>he</sub> = high efficient motor efficiency

Eq17: kWh Savings

$$KWh_{savings} = kW_{saved} \times \text{annual operating hours}$$

Eq18: Total Savings

$$\text{Total Savings} = (kW_{\text{saved}} \times 12 \times \text{Monthly demand charge}) + (kWh_{\text{savings}} \times \text{Energy Charge})$$

Eq19: Simple Payback, Retrofit

$$\text{Simple Payback} = (\text{Labor} + \text{New Motor} + \text{Other costs}) / \text{Total Savings}$$

Eq20: Simple Payback, Repair vs. Replace

$$\text{Simple Payback} = (\text{Other costs} + \text{New Motor} - \text{Rewind Costs}) / \text{Total Savings}$$

An additional consideration for electric motor retrofits and repair versus replace decisions is reliability. Newer energy efficient electric motors are designed more reliably than standard efficient electric motors. Rewound electric motors also carry some reliability concerns including: increased operating temperatures; stator twisting causing soft foot, rotor eccentricity, and stator stress issues; and reduced operating efficiency. Due to the higher potential savings in a repair versus replace scenario, many companies adopt a repair versus replace policy for various sized motors depending on electrical costs per kWh.

### *Variable Frequency Drives*

“When centrifugal pumps, compressors, fans, and blowers are operated at constant speed and output is controlled with throttled valves or dampers, the motor operates at close to full load all the time – regardless of the delivered output. Substantial energy is dissipated by these closed dampers and valves. Significant energy savings can be realized if the driven unit is operated at only the speed necessary to satisfy the demand. Variable speed drives permit optimum operation of equipment by closely matching the desired system requirements.”  
(Rutgers, 1996, p. 4-22)

Most variable frequency drive applications are variable torque applications. In these types of applications, the horsepower varies by the cube of the speed and the torque by the square of the speed, approximately. The actual horsepower and torque can be figured from the torque curves which may be provided with the equipment.

Eq21: Horsepower

$$Hp1/hp2 = (s1/s2)^3$$

As a direct result, energy savings can be considered based upon the required resulting horsepower:

Eq22: kW Used, Total

$$KW = (hp \times .746)/eff$$

Assuming a 250 hp fan operating 160 hours per week, 25% at 100%, 50% at 42% and 25% at 13% load. Assume the motor is 95% efficient, the kWh cost is \$0.05 and demand is \$12/kW.

Ex1: Variable Frequency Drive

$$\begin{aligned} \text{Initial Demand (Eq3)} &= ((250hp \times .746 \times 6 \times 1.5) + \\ &(250hp \times .746 \times 28.5min)) / 30min = 233kW \end{aligned}$$

$$\text{Initial kWh} = 196kW \times 160 = 31,360 kWh$$

$$\begin{aligned} \text{Initial Cost} &= (233kW \times \$12/kW \times 12months) + \\ &(31,360kWh \times \$0.05/kWh \times 52 weeks) = \$115,088/year \end{aligned}$$

*Variable Frequency Drive horsepower equivalent*

<i>%Speed</i>	<i>Hours per Week</i>	<i>%load</i>	<i>Eq. Horsepower</i>
<i>100%</i>	<i>40hrs</i>	<i>100%</i>	<i>250hp</i>
<i>75%</i>	<i>80hrs</i>	<i>42%</i>	<i>105hp</i>
<i>50%</i>	<i>40hrs</i>	<i>13%</i>	<i>31hp</i>

$$VFD\ Demand = (250hp \times .746) / .95 = 196kW$$

$$KWh = (((250 \times .746 \times 40hrs) / .95) + ((105 \times .746 \times 80hrs) / .95) + ((31 \times .746 \times 40hrs) / .95)) = 15,422kWh$$

$$Total\ Cost = (196kW \times \$12/kWh \times 12\ months) + (15,422kWh \times \$0.05 \times 52\ weeks) = \$68,321/year$$

$$Annual\ Savings = \$115,088 - \$68,321 = \$46,767$$

There are also a number of cases where the use of variable frequency drives may be used (constant torque or constant horsepower) for improved production. In either case, variable frequency drives must be properly installed. This can be achieved by following the manufacturer's recommendations.

### *Waste Reduction*

“Almost any operation will generate some sort of waste. Even nonindustrial type of a business will have a waste in terms of paper, cardboard, etc. If the waste is landfilled, it is rather obvious that the space available is limited. If the waste is incinerated, a secondary waste whether in form of unwanted, though more acceptable, substances or at least heat is created. Waste generators need to concentrate on the waste reduction at the source, if that is not possible, recycling is the second choice, and as the last resort, treatment of wastes which will give relatively harmless products.” (Rutgers, 1996, p. 9-1)

The two basic types of wastes are raw materials and packaging and process wastes. Often overlooked are the energy and labor costs associated with landfilled or reworked product. Legal issues, fines, permits, and other special disposal fees may also be included.

“Management of waste related activities, like any other activities, must be conceptualized before any action is taken. All the variables have to be known, including projected amount of waste in the future. The technologies available have to be evaluated. This represents landfills, pulverization, incineration, magnetic separation, paper and plastics recovery, composting, gasification, anaerobic digestion, and so on. After evaluating all options, the overall strategy in waste management has to be formulated and should be based on the most

beneficial technology available. It is advisable, since the economic and political climate may change, to review the chosen strategy periodically and with respect to all existing laws (especially new which could have been enacted after a strategy was selected).” (Rutgers, 1996, p. 9-14)

*To be successful, waste reduction programs must be organized. It is not hard to organize waste reduction, but owners and managers will need to spend a little bit of time at first to get started. Keep in mind the following seven principles of waste reduction:*

- 1. Management must be committed to waste reduction for it to work*
- 2. Businesses should know the types of hazardous waste they generate, how it is produced, and how much is produced.*
- 3. Businesses should know how the hazardous wastes are managed and how much present waste management costs.*
- 4. “Good Housekeeping” reduces spills and other waste*
- 5. Store different waste types in different containers*
- 6. Train all employees in hazardous waste handling and waste reduction methods*
- 7. Be aware of the hazardous materials regulations that apply to the business. Someone should be assigned to keep track of environmental regulations.*



*The five main waste streams generated by industry include:*

- *Solvent Wastes*
- *Water based (aqueous) wastes*
- *Paint wastes*
- *Used oils*
- *Miscellaneous wastes (Rutgers, 1996, p. 9-16)*

### ***Maintenance and Reliability***

A reliability based maintenance program is absolutely essential in today's industrial and manufacturing sites. The requirement is for the process to continue unhampered throughout the production run. This is also known as production uptime, with the opposite being production downtime, or the amount of time the production is off line due to equipment failure.

In a great many cases, equipment maintenance is ignored due to the perception that it is an expense and not a savings for manufacturing. This, of course, is not the case, as a great many companies find out the hard way. Within the Kennedy-Western University Thesis *A Novel Approach to Motor System Maintenance and Management for Improved Industrial and Commercial Uptime and Energy Costs* (Penrose, 1997), the company used to test the thesis began with

an over 26% downtime. Considering this company was a 365 day per year operation, there was a potential of 8,760 hours of production. Due to unscheduled downtime, there was only an actual potential of 6,482.4 hours of production, a difference of 2,277.6 hours of non-productive time. Through the implementation of a scheduled maintenance program, which includes an quarterly 3-day maintenance shutdown, preventive and predictive maintenance program, and partnering with their vendor. Through this approach, which required three years due to budget constraints, the downtime was reduced to less than 6% unscheduled. This resulted in 288 hours scheduled downtime and 508 hours unscheduled downtime. The total difference was an improvement of 1,482 hours. Assuming a cost of \$10,000 per hour (the national average is \$75,000 per hour) on this line, the total annual savings would be \$14.82 million per year in production. The implementation costs were (proprietary information, so costs estimated) \$12k per year training + \$20k per year in preventive and predictive maintenance work + \$25k equipment inventory adjustments + \$100k in new personnel = \$157,000, with annual costs of \$132,000 per year. The preventive and predictive maintenance programs saved an annual corrective maintenance cost of \$60,000 in electric motor rewinds and other equipment repairs.

Once the unscheduled downtime level remained below 6%, the plant was sold to a new national company who determined that they would save money by shutting down the maintenance and management program. The calculated

savings was approximately \$250,000 in reduced personnel and outsourced maintenance programming. Within two years, the unscheduled downtime was reported as approximately 24% +.

### Human Factors in Reliability and Safety

“There are many factors that effect the frequency of human errors. ...Most of the human errors occur because humans are capable of doing so many different things in many diverse ways... 20% to 50% of all equipment failures are due to human errors.” (Koval, 1998, p. 406) In any maintenance system, these issues must be tracked and recorded in order to make modifications to the system to avoid them in the future.

OSHA (Occupational Safety and Health Act) requires employers to provide a safe place to work, safe tools to work with, and competent co-workers. Workers must receive training, supervision, and information on potential hazards to help avoid accidents. Safety related accidents and equipment failures attributed to human error come from either someone knowing better, but intentionally does something incorrect, or that the person does not know better.

Examples of unsafe acts, by personnel, include the following:

- Failure to de-energize, lockout and tagout hazards during maintenance, repair, or inspections

- Lack of safety manuals, instructions, and training.
- Use of defective and unsafe tools
- Use of tools or equipment too close to energized parts
- Removing equipment guards during normal operation
- Removing jams in machines without following safe practices
- Exhaustion due to long hours or high / low temperatures and adverse conditions

Human errors have six basic causes (Koval, 1998, p. 410):

- Design errors can occur at any stage in the life of a system from the original design to installation, operating, and maintenance. Design errors can be attributed to the physical structure of a system with the following three types of inadequacies: failure to implement human needs in the design; assigning inappropriate functions to persons; and, failure to ensure the effectiveness of the man and machine component interfaces.
- Installation errors are primarily caused due to the failure to install the equipment according to instructions or blueprints, assuming the drawings are correct, and poor workmanship when operating under severe time constraints.
- Assembly errors are the result of poor workmanship. Assembly errors are often discovered after the installation process when they disrupt system operations. Some of these errors include: use of incorrect components; use of

incorrect tools; omitting a component; improper connections; and, improper handling of equipment

- Inspection is designed to identify equipment and system defects, and possible hazards in the workplace. It can be determined that the average inspection effectiveness is 85%.
- Operation of any man-machine system is subject to human operating errors, of which include: lack of proper procedures; task complexity and overload conditions; poor personnel selection and training; operator carelessness and lack of interest; poor environmental conditions; and, departure from following the correct operating procedures.
- Maintenance errors are primarily due to the incorrect repair/replacement/service activities of equipment, including: incorrect calibration of instruments; failure to follow maintenance schedules and procedures; and, incorrect equipment cleaning and replacement parts procedures.

### Maintenance System Definitions

There are five basic levels of maintenance to be defined in this dissertation. They are reactive, preventive, predictive, corrective, and proactive.

“The reactive maintenance (RM) concept is one of operating equipment until it fails before performing any maintenance on the equipment. The perceived cost is low, however, this assumption is often correct.

The primary assumption is that by reducing or removing the maintenance organization of a company manpower costs can be reduced. This assumption may hold true for a short period of time (short term view) but does not hold out in the long run (long term view). In many cases, the company may determine that it is less expensive to bring in outside companies on an as needed basis (this does not include sub-contracting a maintenance company) during break downs.” (Penrose, 1997, p. 45).

“Preventive maintenance (PM) is the process of performing the minimum manufacturer recommended, or better based upon corporate history, maintenance and cleaning of equipment. This also includes proper installation, alignment, belt tensioning and balancing of equipment. Basic maintenance training is provided on the equipment and tools used to perform service.” (Penrose, 1997, p. 47)

“Predictive maintenance (PdM) is the practice of taking repeatable readings and being able to trend potential failure of components. Some examples of successful PdM programs include vibration analysis, infrared analysis, and polarization index testing.” (Penrose, 1997, p. 48)

Corrective Maintenance (CM) is the practice of repairing or returning equipment back to its original operating condition. This is usually performed

upon unexpected failure of the equipment and, in some instances, as part of a PdM program to repair / replace equipment before unexpected failure.

Proactive maintenance (PaM) is the practice of preventing equipment failure prior to its life cycle or to detect and prevent repetitive failures. “This is achieved through a complete review of the system in addition to a review of equipment history, RM, PM, PdM, and CM records. In addition, a root cause analysis should be performed in the case of equipment failure in order to determine and correct the cause of failure. If this is not done, the fault is doomed to repeat itself.” (Penrose, 1997, p. 59)

### Incoming Power Considerations

“Few facilities have a management plan for the electrical environment or a general protection philosophy for electronic equipment. Many companies purchase equipment with little or no regard for the infrastructure required to support the equipment. The end user believes that an inexhaustible supply of energy exists on the other side of the electrical receptacle, there must be capacity, and if more receptacles are needed, you can add a strip.” (Lonnie, 1994, p. 21)

*An area not always focused on in an electric motor system is the electrical system. There are a number of areas which both cause increased electrical losses (reduced system efficiency) and decreased reliability, including:*

- *Poor power factor (39%) – is the result of inductive loads causing current to lag behind voltage. This reduces the system efficiency and causes more current to be required to drive a particular load than would normally be necessary. The difference is the power necessary to generate the magnetic field of an inductive load, referred to as reactive power (kVAR). Power factor is measured as an angle or percentage. The best condition is Unity Power Factor (100%, zero degrees).*
- *Power connections (36%) – Caused by: loose terminations; corroded terminations; poor crimps or solder joints; loose pitted or worn contacts; and / or loose, dirty, or corroded fuses. These cause high temperature points in the electrical system as the result of high impedance connections which both causes reduced efficiency / reduced reliability, and potential fire hazards.*
- *Undersized conductors (10%) – Increases the system impedance reducing system efficiency and creating a potential fire hazard.*
- *Voltage Unbalance (7%) – This is where the line to line voltage differs from the average. Electric motors are designed for a maximum of 2% unbalance. Three phase systems must be derated if they are to be found in an unbalanced situation. This condition may be caused by: improper transformer setup; single phase loads; faulty regulating equipment; utility unbalance; open connections; and unequal conductor or component impedance.*



- *Mismatched Motor Voltage (6%) and Voltage Deviation (2%) – Also referred to as Over/Under Voltage – The designed allowable voltage deviation of electric motors is +/- 10%. This may be caused by incorrect motor selection, incorrect transformer settings, or undersized conductors. (Penrose, 1997, p. 34)*

### *Power Factor and Correction*

*Power factor is a measure of how effectively electrical power is being used. A high power factor (approaching unity) indicates efficient use of the electrical distribution system while a low power factor indicates poor use of the system.*

*Many loads in industrial electrical distribution systems are inductive. Examples include motors, transformers, fluorescent lighting ballasts, and inductive furnaces. The line current drawn by an inductive load consists of two components: magnetizing current and power-producing current.*

*The magnetizing current is the current required to sustain the electromagnetic flux or field strength in the machine. This component of current creates reactive power that is measured in kilovolt-amperes reactive (kVAR). Reactive power doesn't do useful "work," but circulates between the generator and the*

load. It places a heavier drain on the power source, as well as on the power source's distribution system.

The real (working) power-producing current is the current that reacts with the magnetic flux to produce the mechanical output of the motor. Real power is measured in kilowatts (kW) and can be read on a wattmeter. Real power and reactive power together make up apparent power. Apparent power is measured in kilovolt-amperes (kVA). (US Department of Energy, 1996, p. 8-1)

Eq25: Power Factor

$$PF = P_i / P_a = \text{Cosine } \mathbf{q}$$

Where: PF = power factor;  $P_i$  = Three phase power in kW;  $P_a$  = Apparent Power  
in kVA

Eq26: Apparent Power

$$P_a = (V \times I \times \sqrt{3}) / 1000$$

V = voltage; I = current

Eq27: Reactive Power

$$KVAR = P_a \times \text{sine } \mathbf{q}$$

Eq28: Real Power

$$P_i = P_a \times \cos \theta$$

$$P_i = P_a \times PF$$

Figure 3: The Power Triangle

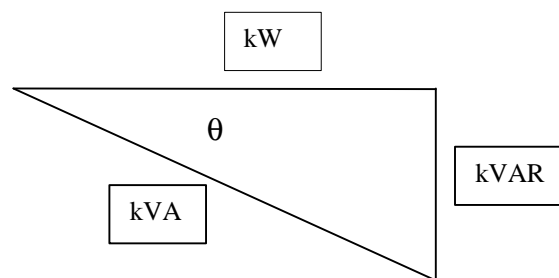

Power factor may be referred to as leading or lagging power factor. In the case of inductive loads, the power factor is lagging (current follows voltage). The amount of lag is the electrical phase angle between the voltage and current.

Several strategies for correcting power factor include:

- Use of the highest speed electric motors that an application can accommodate, as higher speed motors have better power factor than lesser speed motors.
- Size motors as close as possible to the horsepower demands of the load. “A lightly loaded motor requires little real power. A heavily loaded motor requires more real power. Since the reactive power is almost constant, the ratio of real power to reactive power varies with induction motor load, and

ranges from about 10% at no load to as high as 85% or more at full load. An oversized motor, therefore, draws more reactive current at light load than does a smaller motor at full load.” (US Department of Energy, 1996, p. 8-3)

- Add power factor correction capacitors to the in-plant distribution system. Power factor correction capacitors apply leading power factor. By sizing the capacitors for the amount of reactive current, inductive power factor can be reduced.

Table 3: Industries with Typically Low Power Factor

<b>Industry</b>	<b>Uncorrected Power Factor</b>
Saw Mills	45 – 60%
Plastics (extruders)	55 - 70%
Machine Shops	40 – 65%
Plating, textiles, chemicals, breweries	65 – 75%
Foundries	50 – 80%
Chemicals	65 – 75%
Textiles	65 – 75%
Arc Welding	35 – 60%
Cement Works	78 – 80%
Printing	55 – 70%

Several benefits are associated with improving power factor. In areas where utilities charge power factor penalties or charge by kVA, there is a definite benefit in reduced utility bills. In addition, “power factor correction capacitors increase system current-carrying capacity, reduce voltage drops, and decrease distribution system resistance ( $I^2R$ ) losses. Increasing the power factor from 75 percent to 95 percent results in a 21 percent lower current when serving the same kW load. Through adding power factor correction capacitors to the system, additional kW load without increasing line currents, wire size, transformer size, or facility kVA charges. By including power factor correction capacitors in a new construction or facility expansions, you can reduce project costs through decreasing the sizes of transformers, cables, busses, and switches. In practice, however, ampacity ratings are a function of full-load equipment values; therefore, size reductions may be precluded by electrical codes.

Eq28: Electrical Savings by kVA demand

$$KW_{demand} = kVA_{demand1} \times PF_1$$

$$KVA_{demand2} = kW_{demand} / PF_2$$

Where:  $kVA_{demand1}$  = kVA demand before PF correction;  $kVA_{demand2}$  = kVA demand after PF correction;  $kW_{demand}$  = Electric demand in kW;  $PF_1$  = Original power factor;  $PF_2$  = Power factor after correction

Eq29: Based on kW demand

$$KW_{billed} = kW_{demand} \times (.95/PF)$$

Eq30: Percent Reduction in Distribution Losses

$$\%Reduction = 100 - 100 \times (PF1/PF2)^2$$

Where: PF1 = Original power factor; PF2 = Power factor after correction

In addition, when adding power factor correction capacitors, care must be taken to avoid harmonic resonance. “Approximately twenty percent of industrial plants that install and operate capacitors must pay attention to the creation of steady state harmonic resonances. The resonant frequency created with a capacitor and system inductance is calculated by Eq31. As shown in the equations, the square root of the short circuit MVA divided by the capacitor MVAR indicates the resultant harmonic for the system under study. If the resonant frequency is near to an odd harmonic, consider reducing capacitor MVA to bring the system out of tune with that harmonic. This is particularly important if you have a known source of these harmonics. For example, adjustable speed drives can be a significant source of fifth and seventh harmonics.

“Resonant conditions near the 3<sup>rd</sup>, 5<sup>th</sup>, 7<sup>th</sup>, 11<sup>th</sup>, and 13<sup>th</sup> harmonic are usually the most troublesome. Harmonics cause additional noise on the line and

generate heat. This heat can cause failure of capacitors or transformers.” (US Department of Energy, 1996, p. 8-12)

#### Eq31: Harmonic Resonant Calculation

$$H_f = \ddot{O}(MVA \text{ short circuit} / MVAR \text{ capacitor})$$

#### *Power Connections*

“The first step in optimizing your industrial electrical distribution system is to detect and correct any problems due to poor connections. High temperatures are commonly caused by loose and dirty contacts. Such contacts are found in switches, circuit breakers, fuse clips, and terminations. These problems are the most cost effective to correct.” (US Department of Energy, 1997, p. 3-6)

Poor contacts and connections are often caused by:

- Loose cable terminations and bus bar connections (particularly aluminum buswork);
- Corroded terminals and connections;
- Poor crimps and bad solder joints;
- Loose, pitted, worn, or poorly adjusted contacts in motor controllers or circuit breakers;

- Loose, dirty, or corroded fuse clips (or glazing in wet environments)

Detection of these problems are commonly determined through either a voltage drop survey or infrared thermography. Voltage drop surveys can be performed by in-house personnel with existing equipment with the equipment fully loaded. Infrared thermography often requires more expensive equipment, training, but is much faster, more accurate, and safer. Equipment should be at least 40% loaded.

A voltage drop survey involves identifying connections, reading across the contact or termination. There should be no more than a one volt drop across the test point. In addition, the inspector should be looking for:

- Discoloration of insulation or contacts;
- Compromised insulation ranging from small cracks to bare conductors;
- Oxidation of conductors;
- Presence of contaminants;
- Mismatched cables in common circuits;
- Aluminum cables attached to incorrect lugs.

Infrared thermography is performed by using an infrared camera (usually movie). The camera must be able to get a direct view of the components being checked, such as opening cabinets. The camera compares the component



temperature to the ambient, or background, temperature. Following are the values:

- 0 to 10°C: Corrective measures should be taken during the next maintenance period.
- 10 to 20°C: Corrective measures required as scheduling permits.
- 20 to 40°C: Corrective measures required ASAP.
- 40°C and above: Corrective measures required immediately.

#### *Voltage Unbalance*

“Further efforts to optimize your electrical distribution system should include a survey of loads to detect and correct voltage unbalances. Unbalances in excess of one percent should be corrected as soon as possible. A voltage unbalance of less than one percent is satisfactory.

Eq32: Voltage Unbalance

$$V_{avg} = (V_{ab} + V_{bc} + V_{ac}) / 3$$

$$V_{unb} = ((V_{avg} - V_m) / V_{avg}) \times 100\%$$

Where:  $V_{avg}$  = Average voltage;  $V_{unb}$  = % Unbalanced voltage;  $V_m$  = Voltage with greatest difference from  $V_{avg}$

Figure 4: Voltage Unbalance

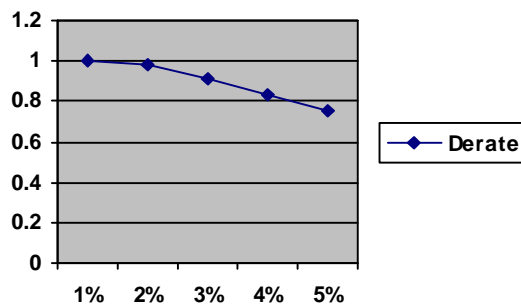

At approximately 3% voltage unbalance, there is at least a 25% increase in operating temperature. The causes of unbalance are often:

- Selection of incorrect transformer taps
- Single phase loads on one phase of a polyphase system
- Unbalanced transformer windings
- Faulty operation of power factor correction equipment
- Unbalanced three phase loads
- Improvements in single phase systems, such as lighting, which reduces the load on a previously balanced system'
- Unbalanced or unstable polyphase supply from the power grid
- Open phase on the primary side of a three phase transformer
- Single phase-to-ground faults

## Motor Starters: Inspection and Maintenance

“A quick visual inspection every six months or so, and less frequent electrical checks with the proper instrument will help ensure that production will not be interrupted because of starter failure that could have been prevented.” (Schermerhorn, 1972)

A flashlight, hose, and small brush are important maintenance tools with motor starters. Debris and dirt can be removed from moving parts, contacts, and other areas of the switch. “Dirt on the pole faces produces an excessive air gap in the magnetic circuit, which causes sections of the core to vibrate with the familiar 60hz hum as the current wave alternately attracts and relaxes the magnetic pull between the two parts of the core.” (Schermerhorn, 1972)

Motor starter contacts should be inspected for pitting and wear. This will reduce the chance of unbalanced voltage or additional arcing and sparking. The primary contaminant is carbon, which is a dielectric. In one case, a 300 horsepower electric motor was seeing varying current, which may indicate broken rotor bars, in other instances. However, the amount of carbon was such that there were continuous small electrical discharges causing repeated slight current increases.

## ***Alternating Current Induction Motor Design***

### Introduction

Electric motor systems consume 20% of all energy generated in the United States, 57% of all electrical energy, and 70% of electrical energy consumed by industry. Over 1.1 billion motors, of all types, are presently in use in the United States at this time.

Induction motors were invented by Nikola Tesla in 1888 while he was a college student. In the present day, induction motors consume between 90 to 95 percent of the motor energy used in industry.

In the first part of our presentation, we are going to discuss:

- The purpose of induction motors
- Induction motor construction
- Operating principles
- NEMA Designs
- Design E motor discussion
- Motor insulation
- Inverter duty motor construction

## The Purpose of Induction Motors

Contrary to popular belief, induction motors consume very little electrical energy. Instead, they convert electrical energy to mechanical torque (energy).

Interestingly enough, the only component more efficient than the motor, in a motor system, is the transformer. The mechanical torque that is developed by the electric motor is transferred, via coupling system, to the load.

The electrical energy that is consumed by electric motors is accounted for in losses. There are two basic types of losses, Constant and Variable, both of which develop heat (Figure 1):

- Core Losses: A combination of eddy-current and hysteresis losses within the stator core. Accounts for 15 to 25 percent of the overall losses.
- Friction and Windage Losses: Mechanical losses which occur due to air movement and bearings. Accounts for 5 to 15 percent of the overall losses.
- Stator Losses: The  $I^2R$  (resistance) losses within the stator windings. Accounts for 25 to 40 percent of the overall losses.
- Rotor Losses: The  $I^2R$  losses within the rotor windings. Accounts for 15 to 25 percent of the overall losses.
- Stray Load Losses: All other losses not accounted for, such as leakage. Accounts for 10 to 20 percent of the overall losses.

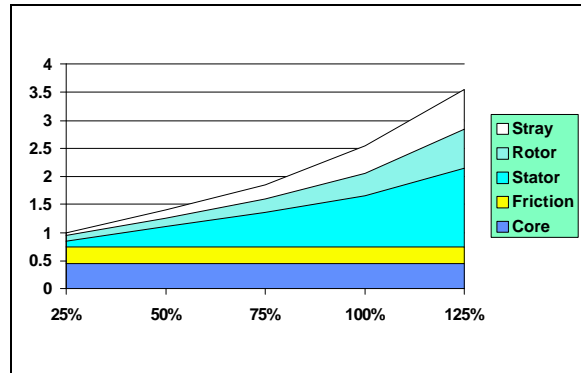

## Induction Motor Construction

An induction motor consists of three basic components:

- ❑ Stator: Houses the stator core and windings. The stator core consists of many layers of laminated steel, which is used as a medium for developing magnetic fields. The windings consist of three sets of coils separated by 120 degrees electrical.
- ❑ Rotor: Also constructed of many layers of laminated steel. The rotor windings consist of bars of copper or aluminum alloy shorted, at either end, with shorting rings.
- ❑ Endshields: Support the bearings which center the rotor within the stator.



## Operating Principles

The basic principle of operation is for a rotating magnetic field to act upon a rotor winding in order to develop mechanical torque.

The stator windings of an induction motor are evenly distributed by 120 degrees electrical. As the three phase current enters the windings, it creates a rotating magnetic field within the air gap (the space between the rotor and stator laminations). The speed that the fields travel around the stator is known as synchronous speed ( $N_s$ ). As the magnetic field revolves, it cuts the conductors of the rotor winding and generates a current within that winding. This creates a field which interacts with the air gap field producing a torque. Consequently, the motor starts rotating at a speed  $N < N_s$  in the direction of the rotating field.

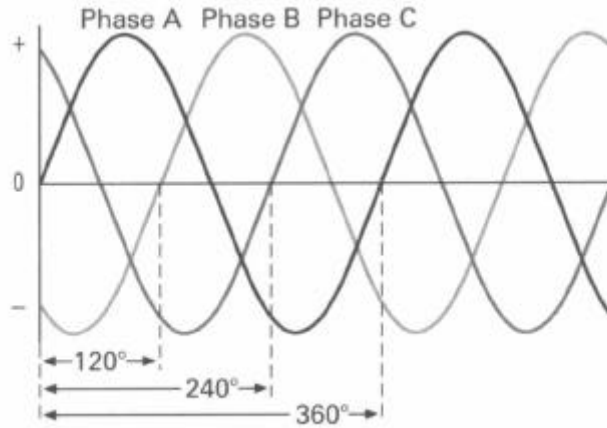

The speed of the rotating magnetic field can be determined as:

$$N_s = (120 * f) / p \quad \text{eq. 1}$$

Where  $N_s$  is the synchronous speed,  $f$  is the line frequency, and  $p$  is the number of poles found as:

$$p = (\# \text{ of groups of coils}) / 3 \quad \text{eq. 2}$$

The number of poles is normally expressed as an even number.

The actual output speed of the rotor is related to the synchronous speed via the slip, or percent slip:



$$s = (N_s - N) / N_s \quad \text{eq. 3}$$

$$\%s = s * 100 \quad \text{eq. 4}$$

## Torque

By varying the resistance within the rotor bars of a squirrel cage rotor, you can vary the amount of torque developed. By increasing rotor resistance, torque and slip are increased. Decreasing rotor resistance decreases torque and slip.

Motor horsepower is a relation of motor output speed and torque (expressed in lb-ft):

$$\text{HP} = (\text{RPM} * \text{Torque}) / 5250 \quad \text{eq. 5}$$

The operating torques of an electric motor are defined as (Ref. NEMA MG 1-1993, Part 1, p.12):

- Full Load Torque: The full load torque of a motor is the torque necessary to produce its rated horsepower at full-load speed. In pounds at a foot radius, it is equal to the hp times 5250 divided by the full-load speed.
- Locked Rotor Torque: The locked-rotor torque of a motor is the minimum torque which will develop at rest for all angular positions of the rotor, with rated voltage applied at rated frequency.
- Pull-Up Torque: The pull-up torque of an alternating current motor is the minimum torque developed by the motor during the period of acceleration from rest to the speed at which breakdown torque occurs. For motors which

do not have a definite breakdown torque, the pull-up torque is the minimum torque developed up to rated speed.

- **Breakdown Torque:** The breakdown torque of a motor is the maximum torque which it will develop with rated voltage applied at rated frequency, without an abrupt drop in speed.

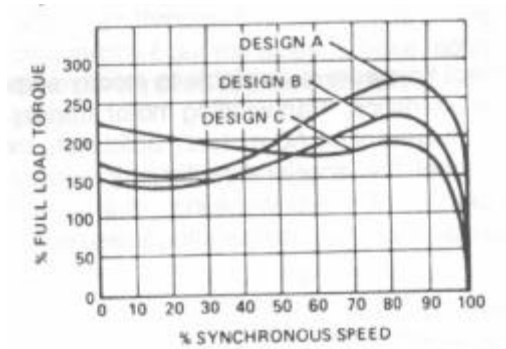

#### NEMA Motor Design Classifications

NEMA defines, in NEMA MG 1-1993, four motor designs dependant upon motor torque during various operating stages:

- **Design A:** Has a high starting current (not restricted), variable locked-rotor torque, high break down torque, and less than 5% slip.
- **Design B:** Known as "general purpose" motors, have medium starting currents (500 -800% of full load nameplate), a medium locked rotor torque, a medium breakdown torque, and less than 5% slip.
- **Design C:** Has a medium starting current, high locked rotor torque (200 - 250% of full load), low breakdown torque (190 - 200% of full load), and less than 5% slip.
- **Design D:** Has a medium starting current, the highest locked rotor torque

(275% of full load), no defined breakdown torque, and greater than 5% slip.

Design A and B motors are characterized by relatively low rotor winding resistance. They are typically used in compressors, pumps, fans, grinders, machine tools, etc.

Design C motors are characterized with dual sets of rotor windings. A high resistive rotor winding, on the outer, to introduce a high starting torque, and a low resistive winding, on the inner to allow for a medium breakdown torque. They are typically used on loaded conveyers, pulverizers, piston pumps, etc.

Design D motors are characterized by high resistance rotor windings. They are typically used on cranes, punch presses, etc.

#### Design E Motor Discussion

The design E motor was specified to meet an international standard promulgated by the International Electrotechnical Commission (IEC). IEC has a standard which is slightly less restrictive on torque and starting current than the Design B motor. The standard allows designs to be optimized for higher efficiency. It was decided to create a new Design E motor which meets both the IEC standard and also an efficiency criterion greater than the standard Design B energy efficient motors.

For most moderate to high utilization application normally calling for a Design A or B motor, the Design E motor should be a better choice. One should be aware of slight performance differences.

Although the NEMA standard allows the same slip (up to 5%) for Designs A, B, and E motors, the range of actual slip of Design E motors is likely to be lower for Designs A and B.

There are a number of considerations which must be observed with Design E motors:

- Good efficiency - as much as 2 points above Design B energy efficient.
- Less Slip - Design E motors operate closer to synchronous speed.
- Lower Starting Torque - May not start "stiff" loads.
- High Inrush - As much as 10 times nameplate full load amps.
- Availability - Presently low as the standard has just passed.
- Starter Availability - Control manufacturers do not have an approved starter developed at this time.
- National Electric Code - Has no allowance for higher starting amps. Design E motors will require changes to NEC allowances for wire size and feed transformers.
- Limited Applications - Low starting torque limits applications to pumps, blowers, and loads not requiring torque to accelerate load up to speed.
- Heavier Power Source Required - High amperage and low accelerating torque mean longer starting time and related voltage drops. May cause nuisance tripping of starter or collapse of SCR field with soft starters.

## Electric Motor Insulation

With all this discussion about motor operation, losses, torque curves, and inrush, it is only fitting to review the thermal properties of electrical insulation. In general, when an electric motor operates, it develops heat as a by-product. It is necessary for the insulation that prevents current from going to ground, or conductors to short, to withstand these operating temperatures, as well as mechanical stresses, for a reasonable motor life.

Insulation life can be determined as the length of time at temperature. On average, the thermal life of motor insulation is halved for every increase of operating temperature by 10 degrees centigrade (or doubled, with temperature reduction).

Table 2: Maximum Temperatures of Common Insulation Classes

Insulation Class	Temperature, °C
A	105
B	130
F	155
H	180

There are certain temperature limitations for each insulation class (Table 3) which can be used to determine thermal life of electric motors. Additionally, the number of starts a motor sees will also affect the motor insulation life. These can be found as mechanical stresses and as a result of starting surges.

When a motor starts, there is a high current surge (as previously described). In the case of Design B motors, this averages between 500 to 800% of the nameplate current. There is also a tremendous amount of heat developed within the rotor as the rotor current and frequency is, initially, very high. This heat also develops within the stator windings.

In addition to the heat developed due to startup, there is one major mechanical stress during startup. As the surge occurs in the windings, they flex inwards towards the rotor. This causes stress to the insulation at the points on the windings that flex (usually at the point where the windings leave the slots).

Both of these mean there are a limited number of starts per hour (Figure 4). These limits are general, the motor manufacturer must be contacted ( or it will be in their literature) for actual number of allowable starts per hour. this table also assumes a Design B motor driving a low inertia drive at rated voltage and frequency. Stress on the motor can be reduced, increasing the number of starts per hour, when using some type of "soft start" mechanism (autotransformer, part-winding, electronic soft-start, etc.).

Table 3: Temperature Limitations

Service Factor	Insulation Temperature	Class B	Class F
1.0/1.15	Ambient	40C 104F	40C 104F
1	Allowable Rise	80C 176F	105C 221F
1	Operating Limit	120C 248F	145C 293F
1.15	Allowable Rise	90C 194F	115C 239F
1.15	Operating Limit	130C 266F	155C 311F

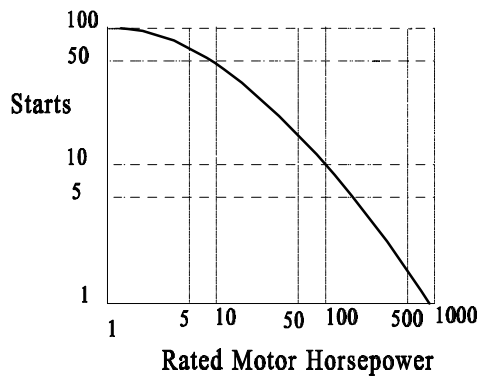

Figure 4: Allowable Number of Starts per Hour

### Energy Efficient Electric Motors

The Energy Policy Act of 1992 (EPACT) directs manufacturers to manufacture only energy efficient motors beyond October 24, 1997 for the following: (All motors which)

- General Purpose
- Design B
- Foot Mounted
- Horizontal Mounted
- T-Frame
- 1 to 200 hp
- 3600, 1800, and 1200 RPM
- Special and definite purpose motor exemption



To meet NEMA MG1-1993 table 12.10 efficiency values. The method for testing for these efficiency values must be traceable back to IEEE Std. 112 Test type B.

Energy efficient motors are really just better motors, when all things are considered. In general, they use about 30% more lamination steel, 20% more copper, and 10% more aluminum. The new lamination steel has about a third of the losses than the steel that is commonly used in standard efficient motors.

As a result of fewer losses in the energy efficient motors, there is less heat generated. On average, the temperature rise is reduced by 10 degrees centigrade, which has the added benefit of increasing insulation life. However, there are several ways in which the higher efficiency is obtained which has some adverse effects:

- Longer rotor and core stacks - narrows the rotor - Reduces air friction, but also decreases power factor of the motor (more core steel to energize - kVAR).
- Smaller fans - reduces air friction - the temperature rise returns to standard efficient values.
- Larger wire - Reduces  $I^2R$ , stator losses - Increases starting surge (half - cycle spike) from 10 to 14 times, for standard efficient, to 16 to 20 times, for energy efficient. This may cause nuisance tripping.

In general, energy efficient motors can cost as much as 15% more than standard efficient motors. The benefit, however, is that the energy efficient motor can pay for itself when compared to a standard efficient motor.

$$\$ = 0.746 * hp * L * C * T (100/E_s - 100/E_e)$$

where hp = motor hp, L = load, C = \$/kWh, T= number of hours per year, Es = Standard efficient value, and Ee = Energy efficient value Eq. 5

### Inverter Duty Motors

Inverter duty motors are specially designed to withstand the new challenges presented by the use of inverters. There are a number of ways to designate motors "inverter duty," however, several things must exist as a minimum:

- ❑ Class F insulation - to withstand the higher heat generated by non-sinusoidal current from the drive.
- ❑ Phase insulation - Insulation between phases is a must to avoid "flashover" between phases from current surges.
- ❑ Layered Conductors - To reduce turn to turn potential between conductors.
- ❑ Solid varnish system - to reduce partial discharge and corona damage.
- ❑ Tight machine tolerances and good air gap concentricity - to reduce shaft currents and resulting bearing damage.

A proper inverter duty motor will have special rotor bar construction designed to withstand variations in airgap flux densities and rotor harmonics. Additionally, the first few turns of wire may be insulated to better withstand standing waves which occur due to the faster rise times in modern inverter technology.

Caution: Some manufacturers may only de-rate motors. This is done by reducing the motor by (about) 25%. Therefore, a 10 hp motor may be rated as a 7.5 hp motor.

It should be noted, also, that an inverter application does not always require an inverter duty motor. The old motor or an energy efficient motor may be sufficient for the application.

### ***Variable Frequency Drives***

#### Variable Torque Loads

Variable loads offer a tremendous opportunity for energy savings with AFD's. The areas of greatest opportunity are fans and pumps with variable loads.

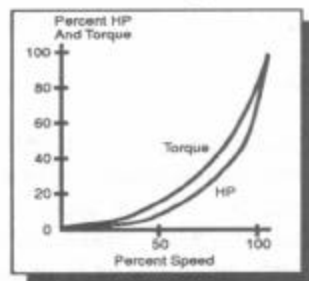

Fan and pump applications are the best opportunities for direct energy savings with AFD's. Few applications require 100% of pump and fan flow continuously. For the most part, these systems are designed for worst case loads. Therefore, by

using AFD's, fluid affinity laws can be used to reduce the energy requirements of the system (Fig. 3).

Fig.3 Pump and Fan Affinity Laws

$$\text{Eq. 1: } N1 / N2 = \text{Flow1} / \text{Flow2}$$

$$\text{Eq. 2: } (N1 / N2)^2 = \text{Head1} / \text{Head2}$$

$$\text{Eq. 3: } (N1 / N2)^2 = T1 / T2$$

$$\text{Eq. 4: } (N1 / N2)^3 = \text{HP1} / \text{HP2}$$

By using the affinity laws, you can determine the approximate energy savings:

Ex. 1: 250hp Fan Operating 160 hrs / Week

$$hp1 / hp2 : (N1 / N2)^3$$

$$100\% \text{ spd} = 40 \text{ hrs} = 100\% \text{ ld} = 250\text{hp}$$

$$75\% \text{ spd} = 80 \text{ hrs} = 42\% \text{ ld} = 105\text{hp}$$

$$50\% \text{ spd} = 40 \text{ hrs} = 13\% \text{ ld} = 31\text{hp}$$

$$kWh / wk = (hp) \times (0.746) \times (hrs / \text{eff})$$

$$250 \times 0.746 \times (160 / 0.95) = 31,411\text{kWh/wk}$$

*Assuming no loss of efficiency at reduced speeds:*

$$(250 \times 0.746 \times (40/0.95)) + (105 \times 0.746 \times (80/0.95)) + (31 \times 0.746 \times (40/0.95)) = \\ 15,422 \text{ kWh}$$

*By using an AFD the approximate kWh savings per year would look like:*

$$(31,411 - 15,422) \times 50 = 800,000 \text{ kWh/yr}$$

### Constant Torque Loads

Direct Current electric motors, eddy-current clutches, transmissions, etc. used to be the best way of controlling process speed. With present AC drive technology, greater speed control and fewer losses can be realized. Additionally, there are fewer moving parts that would have to be maintained.

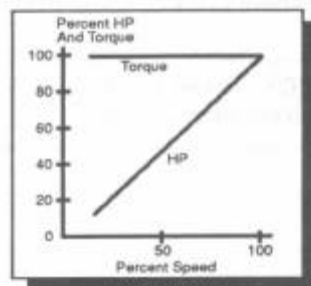

Vector drives can deliver full rated torque from full speed to zero RPM. Torque can be controlled, with precision, allowing even large motors to position loads much like servo motors. This allows for greater flexibility of control over the other methods of speed control.

## Basic Drive System

The AFD consists of several basic components:

- Line Voltage - In this case 3-phase AC voltage.
- Input Section - Consists of a rectifier and filter. Transforms the AC voltage into DC voltage.
- Control Section - The control board accepts real world inputs and performs the required operations. The tasks are performed by a microprocessor.
- Output Section - This section includes the base drive circuits and the inverter. The base drive signals are low level signals that tell the inverter to turn on.
- Motor - Already described.

### Basic Operation of a PWM Inverter (VFD)

In this section we will discuss how the five basic drive system components work together. After this discussion we shall include a detailed, component level, discussion of operation.

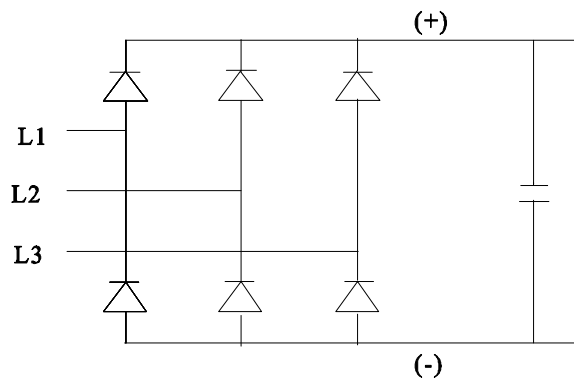

**Fig. 3: Rectifier and Filter**

The rectifier circuit of a pulse width modulated drive normally consists of a three phase diode bridge rectifier and capacitor filter. The rectifier converts the three phase AC voltage into DC voltage with a slight ripple (Figure 5). This ripple is removed by using a capacitor filter. (Note: The average DC voltage is higher than the RMS value of incoming voltage by:  $AC (RMS) \times 1.35 = VDC$ )

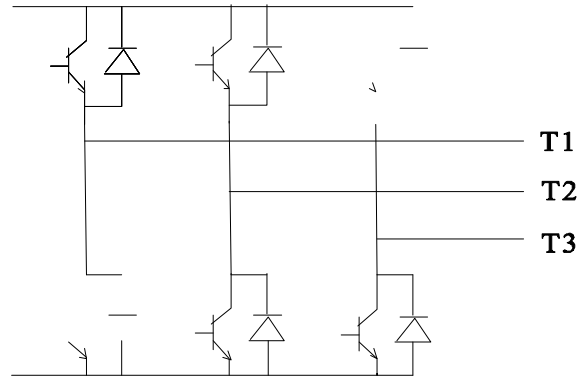

**Fig. 6: Inverter Section**

The control section of the AFD accepts external inputs which are used to determine the inverter output. The inputs are used in conjunction with the installed software package and a microprocessor. The control board sends signals to the driver circuit which is used to fire the inverter.

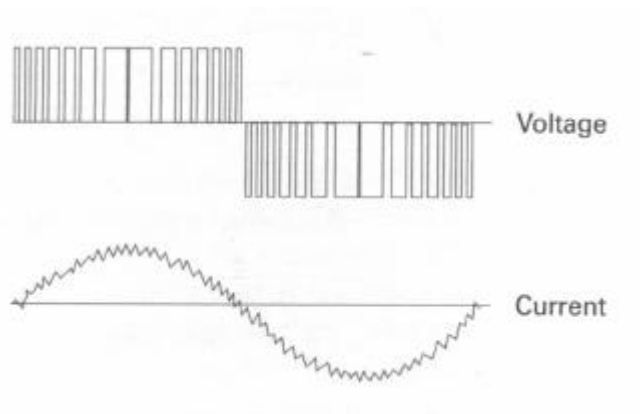

The driver circuit sends low-level signals to the base of the transistors to tell them when to turn on. The output signal is a series of pulses (Figure 7), in both the positive and negative direction, that vary in duration. However, the amplitude of

the pulses are the same. The sign wave is created as the average voltage of each pulse, the duration of each set of pulses dictates the frequency.

By adjusting the frequency and voltage of the power entering the motor, the speed and torque may be controlled. The actual speed of the motor, as previously indicated, is determined as:  $N_s = ((120 \times f) / P) \times (1 - S)$  where: N = Motor speed; f = Frequency (Hz); P = Number of Poles; and S = Slip.

### ***Application Considerations***

#### Variable Speed Concerns

Whenever load speeds are varied, there are many considerations which must be taken into account. These concerns are both electrical and mechanical in nature.

The electrical problems associated with electronic drives generally concern the insulation. Because of the type of output generated by the inverter, there is great stress placed upon the insulation and the temperature rise of the windings may increase. In other cases, the motor may be run below its minimum self-cooling speed. The main trouble is that for every 10 degrees C, the insulation life of the windings are reduced by half. If the temperature rise is allowed to climb too high, the motor will overload and burn-up in a very short time. An additional problem, which is rare, is inverter resonance. These difficulties can be avoided through the following means:



- Rewind or replace the motor - Rewind the motor to a higher insulation class, or replace it with a new motor. the new motor may be of the energy efficient or inverter duty type.
- Provide external cooling - This is especially important in cases where the self-cooling ability of the motor is compromised.
- Re-set the parameters - inverter resonance is found in cases where the drive parameters are not properly set. If this is not the case, the drive should be programmed to by-pass those frequencies where the problems are found.

Mechanical considerations include mechanical resonance and driven load incompatibility. Mechanical resonance can be defined as the speed of the driven load that matches its natural frequency. If this speed is found and maintained, the equipment will develop extremely high levels of vibration and may shake itself apart. Load incompatibility can be defined as loads which may not be operated at speeds lower than their design speed. For instance, many gearboxes have a minimum speed at which the lubricating oil may not be properly moved over the contacting parts.

Mechanical resonance can be avoided by programming the drive to avoid the appropriate frequency(s). The resonance levels may be determined by using a vibration analyzer and operating the machine through the entire speed range. Another way is by performing a "ring-test" using vibration analysis equipment. Load incompatibility can only be avoided by not allowing the drive to operate below a minimum speed.

## Power Quality

Harmonics and electrical noise are potential problems when power electronics are utilized. As more AFD's are put into use, utilities may force users to install harmonic filtering from entering their systems. IEEE Recommended Practices and Requirements for Harmonic Control in Electrical Power Systems; IEEE Std. 519 - 1992; is written to attend to this issue. The standard has been written to limit the harmonic content introduced into the system by either the utilities or the customer.

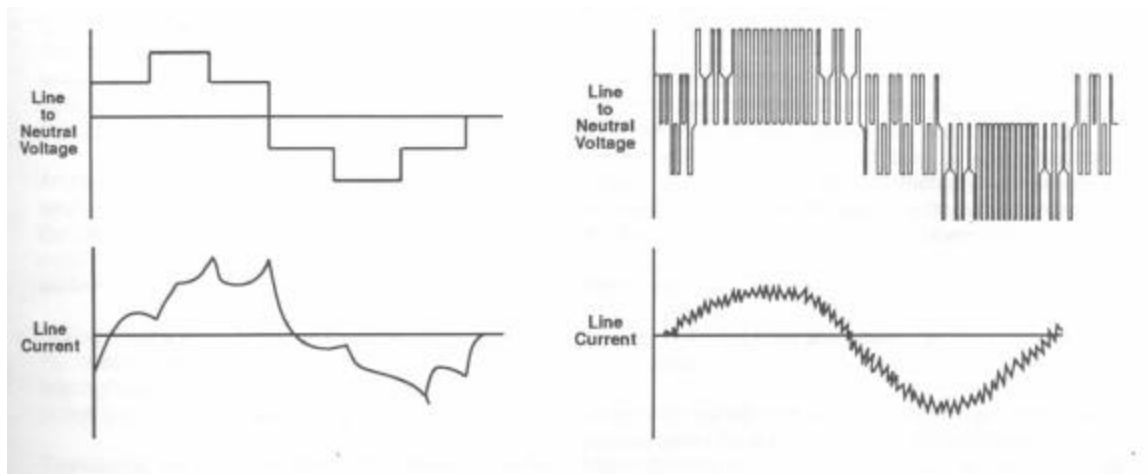

(Note: The limits are, generally, 5% voltage distortion and 3% current distortion at the Point of Common Connection (PCC) or the point at which the utility power enters the customer plant.)

Harmonic content has attracted quite a bit of attention when discussing power quality and power electronics. Harmonics, created by the load, generally come from feedback into the line from electronic power supplies. Voltage and current

harmonics tend to create alternate fields within motors and rotors, cause transformers to overheat, and interfere with other electronic systems. Odd harmonics of the fundamental frequency are generally found in power electronic systems.

In motor systems the following fundamentals of 60 Hz can be recognized:

Harm:	1st	3rd	5th	7th	etc.
Rot:	pos.	zero	neg.	pos.	etc.

Fig. 8: Voltage and Current Harmonics

Positive harmonics rotate in the direction of the rotor. Other than the fundamental frequency, this type of harmonic causes heating within the stator. Negative rotating harmonics rotate against the rotor causing overheating of the rotor and reducing torque. Zero rotating harmonics generally cause system neutrals to overheat. In the case of electronic drives, in general, the predominant harmonics are the 5th and 7th.

#### Inverter Duty Failures

It has been documented that some electric motors fail in inverter applications. This has often been attributed to inverter voltage “spikes.” While this is relatively correct, it misses some important aspects to the mode of failure.

The number of pulses that a PWM drive fires in order to control the current waveform to the drive is known as the carrier frequency. The carrier frequency

tends to run from 2 to 18 kHz in most modern PWM drive. In addition, each voltage pulse is not a square waveform. They have a tendency to overshoot on startup, causing a “ringing” effect at the peak voltage of the pulse. Insulation systems are designed, not only for temperature, but also for “rise time,” how fast the voltage increases over time.

Initially, it was thought that inverter duty failures occurred only on the first few turns of the electric motor winding. It was later found that this was not correct for all cases. Instead, it was discovered, a phenomenon normally seen in electric motors rated at 6,000 VAC, and above, known as Partial Discharge, was now occurring in motors rated as low as 460VAC. This phenomenon is similar to a lightning storm within the windings themselves. Within voids in the winding insulation, charges build up, then discharge (much like a capacitor). The end result is ozone, which begins to break down the insulation on the wires, eventually causing a current path, or short.

The mode of failure for motors in this environment is as follows:

- The motor and drive are placed a distance apart and the carrier frequency is set high (ie: above 8kHz) in order to keep the motor quiet. The lower the carrier frequency the louder the motor noise. No filtering is put in place.
- The pulses from the drive travel out to the motor. Based upon the impedance of the cable and motor, a reflection of the pulse travels back to the drive. This cycles through the “free-wheeling” diodes of the inverter and travel back out with the normal pulses. This adds on to the peak voltage, causing a greater peak (as much as 2 to 4 times, usually 2) with an extremely fast rise time. (ie: less than .1 u-sec per 500 V versus the 1 u-sec per 500 V recommended by NEMA).

- In some cases, the voltage spikes will cause the weakest part of the winding insulation to fail and the motor shorts.
- In other cases, small voids in the insulation begin to have partial discharge problems, the ozone eats away at the insulation, until, finally, the insulation becomes weak enough for the spikes to break through.

It should be pointed out that this tends to be a rare problem. Following are measures to avoid the chance of this problem occurring to you:

- Check with the motor manufacturer to ensure that the motor can operate in an inverter environment.
- Use filters in the inverter system (ie: from line reactors to spike arrestors, designed for inverter use).
- Read the VFD operators manual. It will often state the minimum distances and frequency settings.
- Use proper wire sizes.

### ***Troubleshooting Drives***

“If you are not using an oscilloscope, you are not troubleshooting your drive.”-  
me

#### **Common Problems:**

<u>Problem</u>	Possible Cause	Solutions
The motor will not run	No line power; drive output too low; stop command	Check circuit breakers and drive programming. Check

	present; no run or enable command; faulty drive	for other permissions
Overcurrent or sustained overload	Incorrect overload setting; motor is overloaded	Check overload settings and check to ensure motor is not overloaded
Motor stalls or transistor trip occurs	Acceleration time may be too short. High inertia load.	Lengthen acceleration time. Readjust the V/Hz pattern
Overvoltage	The DC bus voltage has reached too high a level	Deceleration time too short or the supply voltage is too high; motor overhauled by load.
Speed at motor is not correct; speed is fluctuating	Speed reference is not correct; speed reference might be carrying interference	Ensure that the reference is correct and clean.

## ***Mechanical Systems***

### **Bearings**

“Because of the dispersion in life of identical bearings operating under identical conditions, a statistical result will be obtained for bearing fatigue life. For most calculations life is expressed as the number of hours that 90% of a group

of identical bearings will exceed under a given set of conditions, and is referred to as the  $L_{10}$  life.” (Torrington, 1988, p. E-54)

Eq##: Radial Ball Bearing  $L_{10}$

$$L_n = ((16667 * a_1 * a_2 * a_3)/N) * ((f_b * C_e)/P)^3$$

Where  $L_n$  = bearing life in hours;  $a_1$  = life adjustment for reliability;  $a_2$  = life adjustment factor for bearing material;  $a_3$  = life adjustment factor for application conditions;  $N$  = operating speed in RPM;  $f_b$  = dynamic load rating adjustment factor for number of adjacently mounted bearings;  $C_e$  = extended basic dynamic load rating in lbs;  $P$  = equivalent radial load on bearing in lbs

In order to calculate  $a_1$ , follow the table below. This factor accounts for the number of active bearings ( $i_b$ ) mounted adjacent to one another:

Table ##: Dynamic Load Rating Adjustment Factor

$i_b$	1	2	3	4	5
$F_b$	1.00	1.62	2.16	2.64	3.09

The most commonly used reliability level for bearing life calculations ( $a_1$ ) is 90%. Should the application call for greater reliability, see the following table:

Table ##: Life Adjustment Factor for Reliability

Reliability (%)	Ln	A1
90	L10	1
95	L5	0.62
96	L4	0.53
97	L3	0.44
98	L2	0.33
99	L1	0.21

The a2 life adjustment factor for bearing material and the a3 life adjustment factor for application conditions, for the purposes of this dissertation, is 1.

In order to calculate the actual bearing loads it is necessary to know machine component weights and values of all other forces contributing to the load. If it is desirable to know the bearing load imposed by a belted application use the following formulae:



Figure: Bearing Load

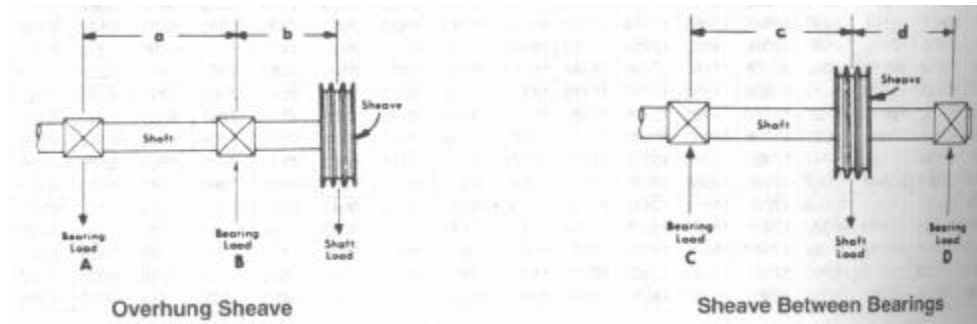

Equation: Overhung Sheave Calculation

$$\text{Load at B, lbs} = (\text{Shaft Load} * (a + b)) / a$$

$$\text{Load at A, lbs} = \text{Shaft Load} * (b / a)$$

Where a and b = spacing in inches

Equation: Sheave Between Bearings

$$\text{Load at D, lbs} = (\text{Shaft Load} * c) / (c + d)$$

$$\text{Load at C, lbs} = (\text{Shaft Load} * d) / (c + d)$$

Where c and d = spacing in inches

Figure: Other Bearing Loading

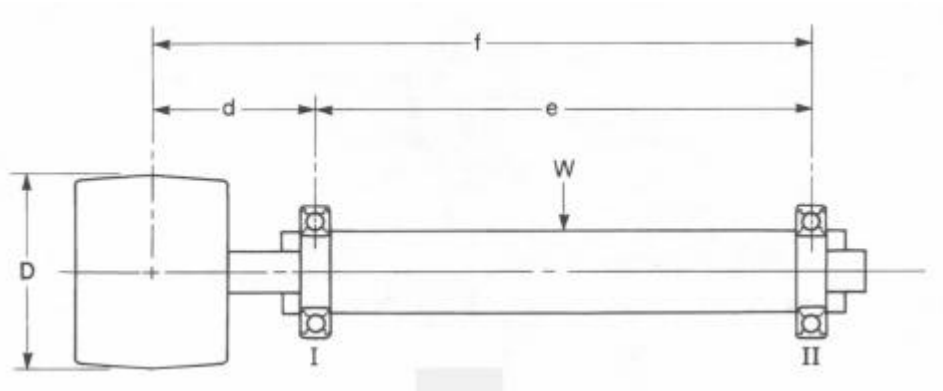

H = Horsepower; R = RPM, W = Weight of Rotor in lbs; D = Diameter of pulley  
in inches

Equation: Belt Pull

$$\text{Belt Pull (B)} = (252,000 * H) / (R * D)$$

$$\text{Radial Load on I} = (B * (f/e)) + (W/2)$$

$$\text{Radial Load on II} = (B * (d/e)) + (W/2)$$

Equation: Vertical Belted Motors

$$\text{Radial Load on I} = B * (f/e)$$

$$\text{Radial Load on II} = B * (d/e)$$

$$\text{Thrust Load on I} = W$$

Equation: Direct Coupled Motor

Horizontal: Radial Load =  $W/2$  each bearing

Vertical: Thrust Load =  $W$  on either bearing

In the case of misalignment in belted or direct drive applications, there will be an increased thrust load. This increased thrust will reduce the life of the system's (not just the motor's) bearings, depending on the types of bearings applied. The amount of thrust is dependant upon the angle of misalignment, speed, and horsepower of the electric motor and the brake horsepower of the load.

### ***Reliability***

“Reliability can be defined simply as the probability that a system or product will perform in a satisfactory manner for a given period of time when used under specified operating conditions. This definition stresses the elements of probability, satisfactory performance, time, and specified operating conditions. These four elements are very important, since each plays a significant role in determining system or product reliability.

“Probability, the first element in the reliability definition, is usually stated as a quantitative expression representing a fraction or a percent specifying the

number of times that one can expect an event to occur in a total number of trials. For instance, a statement that the probability of survival of an item for 80 hours is 0.75 indicates that one can expect the item to function properly for at least 80 hours 75 times out of 100. When there are a number of supposedly identical items operating under similar conditions, it can be expected that failures will occur at different points in time; thus, failures are described in probabilistic terms. The fundamental definition of reliability is heavily dependant on the concepts derived from probability theory.

“The second element in the reliability definition is satisfactory performance, indicating that specific criteria must be established which describe what is considered to be satisfactory. A combination of qualitative and quantitative factors defining the functions that the system or product are to accomplish, usually presented in the text of a system specification, are required. These factors cover system operation requirements...

“The third element, time, is one of the most important because it represents a measure against which the degree of system performance can be related. One must know the time parameter in order to assess the probability of completing a mission or a given function as scheduled. Of particular interest is the ability to predict the probability of an item surviving (without failure) for a designated period of time. Also, reliability is frequently defined in terms of mean

time between failure (MTBF) or mean time to failure (MTTF), making time critical in reliability measurement.

“The specified operating conditions under which a system or product is expected to function constitute the fourth significant element of the reliability definition. These conditions include environmental factors, such as the geographical location, humidity, vibration, shock, and so on. Such factors must not only address the conditions during the period when the system or product is operating, but during the periods when the system is in a storage or being transported from one location to the next. Experience has indicated that the transportation, handling, and storage modes are sometimes more critical from a reliability standpoint than are the conditions experienced during actual system operation use.” (Blanchard, 1990, p.347)

### The Reliability Function

The reliability function is determined from the probability that a system will operate satisfactorily for some specified period of time.

Equation: Reliability Function (R(t))

$$R(t) = 1 - F(t)$$

Where F(t) is the probability that the system will fail by time t

Equation: Distributed Reliability

$$R(t) = e^{-t/\Phi}$$

Where  $\Phi$  is the mean life and  $t$  the time period of interest.

Equation: Mean Time Between Failure (MTBF)

$$R(t) = e^{-t/M} = e^{-\lambda t}$$

Where  $\lambda$  is the instantaneous failure rate and M the MTBF

### Failure Rate

The rate at which failures occur in a specified amount of time is known as the failure rate for that interval. The failure rate per hour is expressed as:

Equation: Failure Rate

$$\lambda = \# \text{ of Failures} / \text{total operating hours}$$

Equation: MTBF (2)

$$\text{MTBF} = 1/\lambda$$

## Reliability Component Relationships

Having a basic understanding of the reliability function and the measures associated with failure rate, it is important to have an understanding of these items in series, parallel, and various combinations.

The series relationship is one of the most commonly used and, therefore, the simplest to analyze.

Equation: Series Reliability

$$R = (R_a)(R_b)(R_c)$$

Or for a given time

$$R = (e^{-\lambda t})_1 (e^{-\lambda t})_2 \dots (e^{-\lambda t})_n$$

A pure parallel network is one where a number of the same components are in parallel and where all of the components must fail in order to cause total system failure.

Equation: Parallel Reliability, where only two identical systems

$$R = R_a + R_b - (R_a)(R_b)$$

Or, for n identical components

$$R = 1 - (1-R)^n$$

For combination systems, break it out into individual components (series and parallel) solve the parallel systems first, then the series systems.

### Related Factors to Reliability

There are several factors which are not directly related to Reliability, but are closely related. These factors include: availability, effectiveness, mean time between maintenance (MTBM) (Blanchard, 1990, p.359):

- Inherent availability ( $A_I$ ): Inherent availability is the probability that a system or equipment, when used under stated conditions in an ideal support environment (ie: readily available tools, spares, maintenance personnel, etc.), will operate satisfactorily at any point in time as required. It excludes preventive or scheduled maintenance actions, logistics delay time, and administrative delay time:

Equation: Inherent Availability

$$A_I = \text{MTBF} / (\text{MTBF} + \text{Mct})$$

Where MTBF is the mean time between failure and Mct is the mean corrective maintenance time



- Achieved Availability (Aa) – Achieved availability is the probability that a system or equipment, when used under stated conditions in an ideal support environment... will operate satisfactorily at any point in time. This definition is similar to the first, except that preventive maintenance is included.

Equation: Achieved Availability

$$Aa = MTBM / (MTBM + M)$$

Where MTBM is the mean time between maintenance and M the mean active maintenance time. Both are functions of scheduled and unscheduled maintenance.

- Operational Availability (Ao) – operational availability is the probability that a system or equipment, when used under stated conditions in an actual operation environment, will operate satisfactorily when called upon.

Equation: Operational Availability

$$Ao = MTBM / (MTBM + MDT)$$

Where MDT is the mean maintenance downtime and includes the active maintenance time, logistics delay time, and administrative delay time.

- System Effectiveness – may be defined as the probability that a system can successfully meet an overall demand within a given time when operated under specified conditions. Or, the ability of a system to do the job for which it was intended.

### Considerations for Reliability

The main purpose of a reliability based maintenance system is to reduce MTBF and MTBM cost effectively. “Thinking of reliability as an engineering problem, one can imagine a team of engineers searching for better equipment designs and working out solutions to eliminate weak points within system processes. When considering reliability from a business aspect, the focus shifts away from reliability and toward the financial issue of controlling the cost of unreliability. Quantifying reliability in this way sets the stage for the examination of operating risks when monetary values are included. Measuring the reliability of industrial processes and equipment by quantifying the cost of unreliability places reliability under the more recognizable banner of business impact.

“It is not a difficult thought process that leads us to the conclusion that higher plant reliability lies in the ability to reduce equipment failure costs. The motivation for a plant to improve reliability by addressing unreliability is clear: Reduce equipment failures, reduce costs due to unreliability, and generate more

profit. It is under this preamble that a sound business commitment to plant reliability begins to step out of the shadows and take shape.” (Dunn, 1998, p. 26)

“Plant engineers and maintenance practitioners typically maintain that good failure data does not exist, or would require extraordinary effort to secure. This is simply not true. Failure data exists all around them in varying degrees of usefulness. Many plants have been accruing failure data under the guise of operating logs, work orders, environmental reports, etc. The force that drives the paradigm is that plant management does not see the data as a tool to solve problems and as a result rarely treats or analyzes the data in an economical manner. This is punctuated by the fact that operators, maintenance personnel, supervisors, and managers fail to acquire data in a manner conducive to analysis.” (Dunn, 1998, p. 28)

### ***Industrial and Systems Engineering***

“Industrial Engineering is concerned with the design, improvement, and installation of integrated systems of people, materials, information, equipment and energy. It draws upon specialized knowledge and skill in the mathematical, physical, and social sciences together with the principles and methods of

engineering analysis and design to specify, predict, and evaluate the results to be obtained from such systems.” (Turner, 1993, p.18)

Industrial engineering has been developed and influenced through an analysis approach known as operations research. This approach originated during World War II as a method for solving production problems through a scientific method “and was aimed at solving difficult war related problems through the use of science, mathematics, behavioral science, probability theory, and statistics.” (Turner, 1993, p.19)

*Industrial and systems engineers design systems at two levels. The first level is ...human activity systems and is concerned with the physical workplace at which human activity occurs. The second is called management control systems and is concerned with procedures for planning, measuring, and controlling all activities within the organization.*

*The human activity system within an organization consists of the following:*

- ❑ *The manufacturing process itself*
- ❑ *Materials and all other resources utilized in the production process.*
- ❑ *Machines and equipment*
- ❑ *Methods by which workers perform tasks*
- ❑ *Layout of facilities and specification of material flow*
- ❑ *Material handling equipment and procedures*

- ❑ *Workplace design*
- ❑ *Storage space size and location*
- ❑ *Data recording procedures for management reporting*
- ❑ *Procedures for maintenance and housekeeping*
- ❑ *Safety procedures*

The management control system of an organization consists of the following elements:

- ❑ *Management planning systems*
- ❑ *Forecasting procedures*
- ❑ *Budgeting and economic analysis*
- ❑ *Wage and salary plans*
- ❑ *Incentive plans and other employee relations systems*
- ❑ *Recruiting, training, and placement of employees*
- ❑ *Materials requirement planning*
- ❑ *Inventory control procedures*
- ❑ *Production scheduling*
- ❑ *Dispatching*
- ❑ *Progress and status reporting*
- ❑ *Corrective action procedures*
- ❑ *Overall information system*

- ❑ *Quality control system*
- ❑ *Cost control and reduction*
- ❑ *Resource allocation*
- ❑ *Organizational design*
- ❑ *Decision support system* (Turner, 1993, p.18)

Several important features of the responsibilities of an industrial engineer, in relation to the purpose of this document, are facility layout and process control. “The planning phase of plant layout is exceptionally important. Since an organization normally must live with the layout for a long time, any mistakes in the actual layout can be very costly. These mistakes should be made on paper long before the physical movement of equipment begins.” (Turner, 1993, p.99) The objective is to develop a layout that minimizes the total cost, however, this term is difficult to define. Some of the components of total cost are:

- ❑ Construction cost
- ❑ Installation cost
- ❑ Material handling cost
- ❑ Ease of future expansion
- ❑ Production cost
- ❑ Machine downtime cost

- In-process storage cost
- Safety cost
- Ease of supervision.

In most cases, issues such as energy are reviewed, but considered a minor item. More “important” issues often revolve around convenience, initial cost, and, hopefully, reduced bottlenecks.

## **Work Measurement**

Another important aspect to the responsibilities of an industrial engineer is work design and organizational performance. “Total organizational system performance has a much broader focus in that it addresses more performance criteria than just efficiency (ie: quality, quality of working life, effectiveness, innovation, profitability, productivity). Work measurement / design in the workplace has a narrow focus in that it addresses efficiency, primarily. In regard to scope, total organizational system performance is concerned with the collection of individuals organized to accomplish a purpose. Work measurement / design concerns itself with the individual person and the person’s interaction with his or her environment.” (Turner, 1993, p.152) Some of the uses of work measurement and design are:

- Determining equipment requirements
- Determining labor requirements
- Designing training methods
- Designing scheduling procedures
- Designing incentive systems
- Gauging work performance
- Estimating cost

A five step process to work methods improvement (or redesign) is as follows (Turner, 1993, p.155):

1. *Selecting a job* – One must select a job to study. This is often done because the job is the most expensive or obviously in need of such a study.
2. *Getting and recording the facts* – The present method of doing the job must be recorded along with other facts such as the frequency of the job.
3. *Questioning every detail* – The present method must be questioned. Some elements may be deleted; most can be changed.
4. *Developing and testing a better method* – from step 3, better efforts may be obvious. These ideas should be developed and tried.



5. *Installing and maintaining improvements* – For the study to be worthwhile an improved procedure must be installed and maintained.

A convenient method of approaching the above steps is to utilize charts. Following are several charts that can be utilized:

1. *Flow Process Chart* – Is the chart of all the activities involved in a process. The following questions should be asked about each task:
  - 1.1. Is this activity necessary or can it be eliminated?
  - 1.2. Can this activity be combined with another or others?
  - 1.3. Is this the proper sequence of activities, or should the sequence be changed?
  - 1.4. Can this activity be improved?
  - 1.5. Is this the proper person to be doing this activity?
2. *Left-hand/Right-hand Charts* – are useful in analyzing the work performed by one person at one specific workstation. As the name implies, the observer follows and times the use of each hand in order to develop an optimum use of the operator.
3. *Flow diagram* – A flow diagram is essentially a flow process chart developed to show the layout of the facility.

4. *Work distribution chart* – is a listing of all activities or responsibilities of every person in a department or group. The objective is to obtain proper balance of assignments and to be certain that the proper level of employment is performing the function.
5. *Operation Process Chart* – The objective is to eliminate unnecessary operations, inspections, or storages and to obtain the proper sequence of them.
6. *Gantt Chart* - Is a horizontal time bar chart that shows relative timing of various activities and is primarily used for scheduling

In most of the cases, an important aspect is the work measurement, or amount of time it takes to perform a task, or group of tasks. Several terms are required for the understanding of work measurement (Turner, 1993, p.165):

- Normal Time – The time required for an average, trained operator to perform a task under usual working conditions and working at a normal pace.
- Normal Pace – The pace of an average, trained, and conscientious operator working over an 8-hour day.
- Actual time – The observed time required for an operator to perform a task.
- Allowances – The amount of time added to the normal time to provide for personal needs, unavoidable delays, and fatigue.

Following are several of the methods for performing these studies:

1. *Direct time study* – Is a work measurement technique in which a physical measurement is made of the actual time required to perform a task using a watch or timer. The measurement times are averaged and modified by considering the operators pace, and finally, allowances are added.
2. *Time Study Standard Data* – Many elements of a task are often repeated throughout an organization. Instead of performing a study of each time such a task is performed, the task can be studied once and the data used as a standard.
3. *Predetermined times* – If jobs or tasks are broken down far enough, there will be a point at which all tasks are made up of the same elements. At this point, time values can be assigned to each task based upon totals of these elements.
4. *Work Sampling* – Is estimating the proportion of time given to an activity and applying to a chart, based upon random sampling of activities.

More often than not, the complete data collected must be reviewed and is time consuming when a large company or process is being reviewed. In these cases, errors can occur if performed manually. Computer simulation is often the solution to this type of problem.

## ***Computer Simulation Techniques***

“No one is certain when the first model was developed, but the principle of using symbolic representations to better understand the interactions of various parts of a system is probably as old as the scientific method. The model puts system components into a form that we are able to comprehend based on known phenomena and allows us to perform experiments that help us predict the behavior of the real system. If the model performs as expected we take satisfaction in having confirmed our understanding of the system under study. Should the model not behave as anticipated, we make changes in the hope of developing a model that will demonstrate that our improved understanding does reflect reality.” (Bateman, 1997, p.1)

“The capabilities of the computer led to significant advances in modeling. First, the flexibility of software enabled researchers to build more complex models than ever before—models which actually represented the system and interactions under study, rather than oversimplified abstractions. Second, the computer’s ability to manipulate large amounts of data with speed and precision encouraged dynamic modeling in which thousands of events are processed in a small fraction of what would be required in real time... Thus, models could be developed of systems which were both complex and dynamic.” (Bateman, 1997, p.1)

At this point, large amounts of data may be processed, utilizing models which represent, both graphically and mathematically, the real world system. By utilizing information gathered as part of a study of a service, process, or combination, an accurate understanding of the system may be achieved.

“Simulation is a means of experimenting with a detailed model of a real system to determine how the system will respond to changes in its structure, environment or underlying assumptions. A system, for our purposes, may be defined as a combination of elements which interact to accomplish a specific objective. A group of machines, each of which performs some function in producing a part, would constitute a manufacturing system. Each such combination of elements comprises a subsystem of yet a larger system....”

“The builder of simulation models should never forget that simulation is a problem solving tool. To the extent that a well constructed model helps to answer important questions, simulation can be a powerful and useful technique.”  
(Bateman, 1997, p.2)

Before a simulation project is initiated, two important questions must be answered: 1) What is the scope of the model / simulation? And 2) What level of detail is required? An obvious area of concern is that the modeling and simulation experiments are maintained as cost effectively as possible. It is not, for instance, cost effective to develop models and simulation for the sake of development. You must first have a question to answer. For instance, suppose an

area of a manufacturing concern is identified as having cost and quality issues. If they cannot be readily identified through other means, or are found to be complex issues, simulation may be used to determine which measures may be taken for the least negative or optimized changes.

The primary purpose of utilizing computer simulation is to determine the best-cost or effective approach on computer so as to reduce risk to the decision making process. If, for instance, it is identified on a production line that a \$250,000 project would save the company over \$1 million the first year, and each year thereafter. In order to reduce the risk on performing the changes and having a disaster occur, the system can be modeled and simulated with the changes in place in order to determine whether it may be successful or not.

“Even the most exhaustive of studies will be less valuable if it does not address a current need. Generally, the most effective model is one which considers only those parts of the system that need to be studied in order to provide answers to an existing or potential problem. Although any good simulation modeler will attempt prepare a model which can be expanded easily to include other parts of the system which may merit future study, unnecessary inclusion of extraneous detail results in high modeling costs, slower response times to the problem at hand and computer runs which are much slower than would otherwise be possible.

“Obtaining a concise and accurate definition of the problem to be studied may be more difficult than anticipated. Often, the modeler is not the only person with an interest in the outcome of the study. Engineers, managers, operating personnel, and others may have their own agendas and expect different information from the model. An effort to obtain common agreement about the nature of the study and its scope will normally result in better support from those who must provide data and other assistance.” (Bateman, 1997, p.33)

Problem definition can be time consuming if not properly handled. Selecting the process to be studied and the interested / affected parties is the first and most necessary part. The process and the associated problem should be reviewed in a brain-storming session – in a few cases, these sessions would resolve the problem.

It is also important not to take the information provided from opinion or general statements as fact. Often, the person presenting the information will present the data from his/her own paradigm, which may be part of the problem. It is best to accept this information and weigh its value based upon empirical evidence. For instance, suppose a study is being performed on a service provider and a brain-storming session identifies an area of potential within an area within the service system. However, the supervisor of that area feels (consciously or unconsciously) that the issue would show that he is not effective at his / her job, or has conservative views on the process (it has always been done this way). That

person may insist that changes cannot occur for some 'legitimate' reason. If this position is followed, opportunities within that area may be missed.

In another case, brain-storming sessions and process improvement without the assistance of process improvement may become costly and time consuming. Take, for instance, an issue where a management facilitator with limited experience in service process improvements sets up weekly meetings to study certain areas within a service plant. These meetings tie up approximately ten key employees per session and last 120 minutes per week. Over a three month period (15 weeks) one specific area is identified and brain-stormed. An idea is generated, based upon the collective opinion of the group and is implemented over the next four weeks tying up 5 personnel 2 hours per week plus weekly 60-minute meetings of the process group to discuss the success of the issue. It is found that there is no noticeable savings:  $((15\text{wks} * 10\text{persons} * 120\text{min/wk}) + (4\text{wks} * 120\text{min/wk} * 5\text{persons}) + (4\text{wks} * 60\text{min/wk} * 10\text{persons})) / 60\text{minsperhr} = 380$  hours. However, with process simulation, there would have been one 4-hour brain storming session to identify and outline the problem, 20 hours of data collection, and 30 hours of modeling and simulation. Occasional questions would be requested of the affected personnel, totaling 1.5 hours. Total would have been 91.5 hours, a savings of 288.5 hours, not including the savings of the effectiveness and availability of the 10 persons. Assuming \$60 per hour costs, the direct costs would have been \$22,800 for the first scenario and \$5,490



for the second scenario, a savings of \$17,310. (Note: True example, name of company and situation withheld).

There are a number of standard applications for computer simulation.

Those are:

- *Time* – One of the more popular uses of computer simulation is to improve competitiveness through time improvements and rapid changes to processes. This becomes more important when following issues of Just-In-Time (JIT) for manufacturers, as well as inventories.
- *Material Handling* – by modeling material handling issues, the simulation model can review the effectiveness of the system and project the performance of transport devices in a variety of situation.
- *Plant Layout and Capacity Planning* – simulation and modeling can be used in the planning and construction of new facilities to ensure that there is sufficient capacity for production goals.
- *Job Shop Scheduling* – “... job shops may manufacture a variety of items using the same machinery, equipment and work force. Probably the most incessant challenge faced by managers of these companies is the ability to meet customer delivery requirements while trying to utilize their own resources more effectively.” (Bateman, 1997, p.115)

- *Capital Equipment Evaluation* – by including new technologies or processes in a model of an existing operation, management can determine the impact of the technology on the system.
- *Staffing* – By simulating existing systems best cost staffing can be determined in many environments.
- *Procedures Improvement* – Through simulating existing procedures and reviewing how they interact, those procedures may be reviewed in such a way as to cut down on time, or improve record keeping and traceability.
- *Warehousing and Distribution* – Can be used to determine best methods and locations for the handling of parts and materials as well as finished goods.
- *Order Processing* – Improved methods of handling customer orders through a review of the processes for handling customer orders.
- *Maintenance* – Help determine maintenance system paybacks based upon planned and unscheduled downtime.
- *Environmental* – simulation is being used more and more in areas of environmental cleanup and handling of waste materials.

One of the important aspects of simulation is cost justification. “To assess the benefits from a simulation investment, as with any form of analysis, subjective and objective factors must be considered. Both tangible and intangible benefits must be carefully evaluated. A consistent, logical approach is necessary to assess

the benefits of simulation. The major steps that are included in a justification methodology are to 1) collect and 2) process meaningful data for analysis, 3) evaluate the results, and 4) present justification results in a meaningful report.

“To prepare an assessment of the savings from using simulation, it is necessary to identify the tasks and areas that will be “impacted” by simulation. Only those areas that experience a change in cost of required resources should be considered in the analysis. The intent of the justification analysis is to see the effects of simulation on the cost and quality of problem solving.” (Bateman, 1997, p.127)

The primary areas of impact would be manpower and operations. As in our earlier example, simulation can directly influence manpower resources involved with problem solving. This would be the costs directly involved in the utilization of personnel for simulation versus other measures. You would also obtain the overall cost for the task and compare those costs to the expected impact areas, cost and productivity improvements, avoided costs, and any other incurred costs. The end result of computer simulation is the ability to review many options in order to select the option with the greatest value and least risk.

## **Chapter 3: Research Method**

### ***Project Approach***

This project shall consist of four stages with the final conclusion consisting of a novel approach to energy, waste, and process improvements guidelines and formwork. The four stages shall consist of:

1. Selection of a computer process simulation software to fit the scope of the project.
2. Perform a standard energy efficiency and waste stream survey of a processing plant. In this case it shall consist of a confectionery company.
3. Perform a rotating equipment maintenance and reliability survey of a coal fired power plant.
4. Perform a complete energy, waste, reliability, and computer simulation survey of a processing plant. In this case it shall consist of a bakery.

Due to confidentiality agreements, specific information on processes, reliability, and energy costs cannot be included in the final report.

## **Data Gathering**

### Stage 1: Process Simulation Software

A team of students from the Industrial Engineering department of the University of Illinois at Chicago (UIC) College of Engineering shall be selected for this stage as a Senior Design Project. The team (IET – Industrial Engineering Team) shall consist of five senior students: Rob Miller, project leader; Ghiath Al-Chaar, simulation leader; Gail Gueco; Ed Soto; and, Aaron Horton. All five have completed computer simulation classes at UIC and will be reviewing the software available at UIC (Arena V. 3.0) and other process simulation products. Their efforts will be included as part of an Illinois Department of Commerce and Community Affairs Project on Energy Improvements in the Illinois Food Processing Industry (SIC 20). The UIC Energy Resources Center has agreed to purchase a copy of the software selected. Selection criteria include:

1. Ease of use
2. Graphical representation of processes
3. Information presented
4. Model development time

5. Industry cost for the software.

Three software packages will be selected and reviewed using the same or similar models and information. The results will be compared to Arena, the present UIC process simulation software.

Stage 2: Confectionery Company Survey

A complete energy audit shall be performed of an industrial food processing plant following the basic methodology of the Rutgers Modern Industrial Assessments Manual (Rutgers, 1995). The industrial audit team shall consist of UIC Energy Resources Personnel, Illinois Department of Commerce and Community Affairs Energy Engineers, and ComEd Energy Engineers. Howard W. Penrose shall act as the Project Engineer, as well as data collection and assemble the final report.

Stage 3: Power Plant Rotating Equipment Survey

The UIC Energy Resources Center shall perform a rotating equipment inventory and review of existing systems based upon A Novel Approach to

Electric Motor System Maintenance and Management for Improved Industrial and Commercial Uptime and Energy Costs (Penrose, 1998). This project is funded by Dreisilker Electric Motors, Inc. of Glen Ellyn, Illinois, and will include complete recommendations for the implementation of a Motor System Maintenance and Management Program and reliability measures.

#### Stage 4: Bakery Project

As part of the Illinois Department of Commerce and Community Affairs Food Processing in Illinois (SIC 20) project, Judy's Bakery has been selected to be the site for the complete energy, waste stream, and process improvement for improved energy and competitiveness. The student IET team shall perform the complete survey, following concept and safety training to be performed by Howard W. Penrose. This will remove the potential errors to the new methodology by performing the survey without energy survey experience. Time studies, process flow, and computer simulation studies shall be performed. The initial condition shall be modeled, a low-cost model, and a complete redesign of the process. From the initial overview of this site, it is expected that improvements in excess of 33% product flow with no increase in energy can be found.

## Grain Miller Survey

A large Illinois corn and grain miller is to undergo a complete industrial audit in two phases. In the first phase it will be evaluated for best opportunities and in the second a selected portion of the plant will be surveyed for potential energy, waste stream, productivity, and reliability.

## Data Review

The results of the new concept shall be reviewed and weighted against the cost-benefit ratio of performing such a survey. Depending on findings, one of two methodologies may be adopted: process simulation standards for all energy, waste stream, and process improvements; or, preliminary selection for process simulation, when conditions warrant.

## Originality and Limitations

The process simulation approach for energy, waste stream, process, and reliability improvements is a novel approach. Upon conclusion of this project it is expected that at least the UIC Energy Resources Center and the Illinois



Department of Commerce and Community Affairs will adopt the new methodology for all industrial energy surveys. The project conclusions will be limited as to be generic across process industry boundaries.

## **Chapter 4: Data Review**

The five industrial assessment tasks were performed as outlined. The primary observation was that a pre-assessment can be performed based upon the experience of the personnel performing each study. The basic steps to performing the type of industrial audits outlined within this dissertation are:

1. Selection of an assessment site.
  - 1.1. Obtain one year of energy and waste bills.
  - 1.2. Obtain one year of incoming materials and shipping weights.
2. Perform a basic walk-through of the industrial or commercial site.
  - 2.1. Observe plant lighting and lighting placement.
  - 2.2. Observe personnel and general worker enthusiasm.
  - 2.3. Look for energy, waste, production, and maintenance based posters or charts mounted in an area that can be observed.
  - 2.4. Review any existing energy, waste, production, and maintenance records.
3. Determine best approach to assessment. Some plants will require a focus on energy, waste stream, production, and / or reliability and maintenance.
4. Perform the study based upon the initial observations. In some cases, additional issues may become apparent during the study.
5. Review and provide report.

### ***Selection of Process Simulation Software***

In the first phase of the study selection of a process simulation software was required. This software was to be used to study the process at selected industrial facilities in order to determine the best approach for energy, waste stream, production, and maintenance and reliability. The purpose of the software was to allow a study to eliminate waste, organize the work place, study work flow, and review total productive maintenance while being able to observe the impacts using graphics.

When reviewing general waste reduction, the areas which must be reviewed when selecting simulation software is consideration for:

- ❑ Over Production – which, in general costs money through inventory carrying costs, excessive space, extra overheads, people, and paperwork.
- ❑ Waiting time (queuing) – Is identified as non-value added time that can be used for other functions.
- ❑ Transportation – Poorly planned layouts and process flows. This also includes layout deficiencies.
- ❑ Processing – Extra labor for rework or excessive material usage when fixtures, molds, etc. are not properly designed and maintained.
- ❑ Inventory – Companies may still use inventory as an insurance policy against other production and/or reliability deficiencies.
- ❑ Motion – Time not spent on performing process work results in motion loss, for example, improper tool layout for a workstation.
- ❑ Product defects – Defects cause more than just material and rework costs. They also cause reduced customer confidence and delivery costs.

Work place organization has an impact on reducing all wastes present within a process, being able to visualize the layout and application of the system allows for:

- ❑ Simplification of processes and production requirements.
- ❑ Organizing the workplace and reduce reaching or other motion related problems.
- ❑ Keep equipment and work areas clean.
- ❑ Perform proper maintenance and reliability tasks.

With the simulation software, the work flow must be able to be studied and variations examined with ease.

In order to examine the software requirements for this project, a team of industrial engineering students dubbed the Industrial Engineering Team (IET) was organized. The rest of the selection team included: Howard W. Penrose, advisor; Dr. Wei Chen, Operations Specialist; and, Dr. Kyuil Kim, Industrial Simulation and Automation Specialist, all of the University of Illinois at Chicago's ME/IE and Energy Resource Center College of Engineering departments.

The general consensus was that the following rules would apply to the review and selection of the software package:

- ❑ Ease of use and the ability to self train.
- ❑ Graphics – The user must be able to demonstrate the process to persons not familiar with the numerical outputs of the simulation software.
- ❑ Accuracy of output.

- ❑ The ability to perform multiple analysis and to demonstrate several different approaches with comparisons.
- ❑ Support from the software company.

A number of manufacturers were contacted for demonstrations of their software packages. Primarily this contact was performed through the manufacturers' websites. In all, over 50 manufacturers were contacted with less than ten responding in any acceptable time. Within these responses, only three were found to meet the minimum requirements outlined by the group.

The three remaining software packages included: SimCAD, of Naperville, Illinois; Arena 3.0; and, ProModel. While SimCAD was developed by a local company, they did not have the marketshare that the IET group felt comfortable with. The remaining software programs were subject to a simulation of a health club in order to determine accuracy. It was determined that the Arena software did not maintain the graphics necessary to support a visual presentation, without a great deal of work. As a result, ProModel was selected as the premium software package for use by the IET project.

### ***Confectionery Company Industrial Survey***

The first industrial assessment was performed on a large Chicago confectionery company and funded by the Illinois Department of Commerce and Community Affairs. During the initial walk-through it was identified that a great many of the potential energy, waste, production, and reliability issues were already being resolved. Therefore, the primary position of the study was to evaluate the present

condition of the company, with opportunities identified as the project moved forward.

The facility was over one million square feet of, primarily, air conditioned space. A lighting survey had previously been performed and had been almost completely implemented. The company had also installed co-generation and were in the process of converting their older cooling / chiller systems. The processes, in general, were in excellent shape, with little or no opportunities that could be studied within the scope and budget for the project. Waste streams were well documented and a reward system for waste stream reduction was implemented. The remaining primary opportunities were electric motor systems and reliability improvements.

### Energy Consumption

Over the period of 1998, over 263,825,988 Mega-Joules of energy was consumed by the confectionery company. Of this, 80% was electrical use, 20% boiler steam, with less than a percent as process natural gas and #2 fuel oil. Of the electrical energy, 45% was generated with a four Mega-Watt, 13.8 kilo-Volt turbine generator, with the remaining 55% purchased from the local electrical company.

Electric motors were found to consume 72.3% of all of the energy and 91% of the total electrical energy. Lighting made up 5% of the total electrical energy and all others, including packaging, used 4%.

It was determined, through the study, that it took 2,967.1 MJ of energy to make one ton of product.

#### Electric Motor Energy Conservation

By far electric motors provided the greatest opportunity at the company. Through the introduction of a MotorMaster Plus survey of over 900 electric motors, it was determined that 92% of the motors surveyed did not meet the minimum requirements as energy efficient electric motors. The average loading of the motors was 71.6%, with a majority of the smaller electric motors (less than 50 horsepower) being 30% loaded and the larger motors (greater than 100 horsepower) tending to be fully or overloaded.

It is highly recommended that a Repair versus Replace program was to be implemented for all motors at the company. It was also recommended that a number of electric motors were to be immediately retro-fitted with premium efficient electric motors. In both cases, the highest efficient and best cost motor

manufacturers should be selected. Best cost being defined as the best price for the greatest reliability.

Following is a bulleted list of electric motor recommendations identified by the study:

- ❑ Review electric motor management practices and agreements to ensure that the best cost and best efficiency motors are being provided.
- ❑ Immediately implement a repair versus replace program. Almost every motor in the plant would see immediate paybacks as a result.
- ❑ Retrofit all electric motors that were identified by the MotorMaster Plus survey with a simple payback of less than five years.
- ❑ Overloaded and underloaded electric motors must be identified and replaced. These conditions have a negative impact on both the plant power distribution system (poor power factor) and equipment life due to overheating. For instance, a number of process motors had a life span of approximately one year, through the survey the motors were determined to be overloaded (along with stresses inherent with inverter duty) which appears to have been the primary culprit.



## Steam Trap Opportunities and Improvements

The steam trap survey performed identified a steam trap failure of 11%, with a resulting cost of \$18,422 per year (4,605.6 klbs steam per year). Exactly half of the failed steam traps were blowing through and the other half were leaking. The payback on repairing the ten bad traps was immediate. However, a failure of 11% was to be considered unacceptable failure rate and the frequency of inspection was recommended to be increased to quarterly.

## Reliability and Maintenance Opportunities

Based upon the history of the particular confectionery firm, it was quite surprising to observe a number of opportunities within the reliability and maintenance departments. Based upon general observation, and observed workload, the reliability department could utilize at least one additional reliability technician. Observations included: 1) vibration data collectors were sitting idle in the reliability department throughout the period of the study (five weeks); 2) a failed glycol pump located near food took in excess of a week to repair; and, 3) key process motor failure rates. The justification for increasing manpower was as follows:

- ❑ Improve verification and inspection of repaired equipment. By catching warranty issues before installing equipment, the reliability department can save at least two hours per twenty motors.
- ❑ Improved measurement and effectiveness of maintenance programs could save approximately 100 man-hours per maintenance technician per year.
- ❑ Vibration analysis and other predictive maintenance measures that had dropped off could save at least \$31,500 per year, not including production downtime savings.
- ❑ Improved root cause analysis with just the failed motors studied alone would have saved at least \$18,250 per year in unnecessary repair expenses due to annual winding and bearing failures. The apparent cause of the process motor failures was an incorrect use and application of motors and drives. The analysis to determine the cause of unreliability took approximately one man-day including data collection. It was recommended that the electric motors were changed to 1800 RPM versus the existing 900 RPM motors and that the drives were adjusted to 30 to 80 Hz versus the existing 60 to 140 Hz. This change would amount to an immediate payback.
- ❑ Establish an electric motor maintenance and management program. Because electric motors were so critical to the day to day operation of the company, it was highly recommended that a motor management program become established based upon A Novel Approach to Total Motor System Maintenance and Management for Improved Commercial and Industrial Uptime and Energy (Penrose, 1998).

The total recommended cost for implementation of all study recommendations was \$3,092,710 for a savings of \$1,355,347 per year resulting in a 2.3 year simple payback.

## Methods and Formulae Utilized

In order to provide a unified energy profile, the energy had to be converted to a common unit. Normally this unit would have been BTU (British Thermal Units), but, as the information was provided by the firm in Mega-Joules (MJ), it was determined that this would be the best method. This value could be easily converted to kWh (kilo-Watt-hours) and Btu's as necessary. The resulting breakdown of electrical and gas use was determined using kWh and Btu's as kW demand was unavailable for study. Only 8% of the electric motors at the plant were surveyed for load profile, leaving a level of uncertainty to the actual percentage of motor use.

The US Department of Energy software, MotorMaster Plus, was used for the evaluation of the electric motors at the company. The cost savings analysis capabilities of the software identified the greatest opportunities to be realized at the company.

The three methods used to test the steam traps at the company were: 1) Visual (leaks only); 2) sound; and 3) temperature. Following are brief descriptions of these three methods:

### Visual Method

Visual observation, when possible, is the best method to check trap performance. Unfortunately, in most cases, the trap discharges into a closed condensate return system, making visual checking difficult. A test valve or sight glass should be installed downstream of the trap to alleviate the problem. In order to check trap performance, the isolation valve is closed to shut off the condensate return line, and the test valve is opened. If flash steam and condensate as the trap cycles, the trap is operating properly. If the steam that accompanies the condensate is live steam, discharging at high temperatures and at high velocity, the trap has failed.

### Sound Method

Since most traps do not have a test valve located near them, they can be tested by listening to them carefully as they operate. To be accurate the sound method requires the use of a listening device. Usually an industrial stethoscope, such as the ultrasonic tester used by the Illinois Department of Commerce and Community Affairs energy engineers utilized in this study. However, screwdrivers or wooden dowels have also been used to amplify the sounds.

For most traps, the operation could be monitored when the stethoscope is placed against trap near the discharge orifice. In order to cross check the results, traps that are suspected to be bad should be checked with the visual or temperature method.

The sound method of testing traps, if performed by trained personnel, can yield reliable information. However, the reliability of this method is not as good as the visual method.

#### Temperature Method

The function of a steam trap is to allow condensate to pass while holding back steam. This would imply that there is a significant temperature differential between the steam side and the condensate side of a properly operating steam trap. A widely used rule-of-thumb is that a temperature difference of less than 30 degrees indicates that a trap is functioning properly. However, since a gas which is allowed to drop to a lower pressure undergoes a corresponding drop in temperature, this method is not necessarily accurate.

The temperature method involves making surface temperature measurements in the pipeline immediately upstream and downstream of the trap. To accomplish this, a contact pyrometer is needed as well as knowledge of the line pressure both

up and downstream. The following table shows some typical pipe surface temperatures with corresponding operating pressures:

**Table 1: Pipe Surface Temperature Versus Steam Pressure**

Steam Pressure	Steam Temperature	Pipe Surface Temperature (F)
15	250	238-225
50	298	283-268
100	338	321-304
150	366	348-329
200	388	369-349
450	460	437-414

Note that the pipe surface temperature is generally 15 to 20 degrees F below the actual steam temperature. For example, assume a steam-wide pressure of 50 psig and a downstream pressure of 15 psig. A properly maintained trap should show pipe temperatures of 270 degrees upstream and 230 degrees downstream.

The temperature measurement method is a rough estimation of the trap's operational performance. The data gathered by this method should not be relied upon as being totally accurate. Cross checking with the sound method is suggested.

Reliability Program Opportunities and Recommendations

The reliability group consisted of two reliability technicians and one support technician. In the past the group was reinforced with one to two additional personnel. One key observation made by UIC-ERC personnel was the idleness of

two vibration data collectors in the reliability office. A second observation was of one glycol pump located close to product. This particular pump was vibrating enough to shake the attached piping as well as making failed bearing or pump impeller sounds. The failed pump was reported to maintenance, but was still found to be failed and vibrating close to product one week later.

The above conditions raise two distinct issues:

- ❑ Reliability effectiveness and manpower
- ❑ Maintenance effectiveness and manpower

The reliability and maintenance personnel were observed performing numerous tasks on production lines, equipment upgrades and projects, and new equipment validation and commissioning. These are, of course, normal responsibilities of the reliability department, as well as:

- ❑ Verifying and inspecting repaired equipment
- ❑ Measuring the effectiveness of maintenance programs
- ❑ Performing predictive maintenance programs, such as vibration analysis
- ❑ Performing root cause analysis of equipment failures
- ❑ Scheduling planned downtime for planned maintenance

Unfortunately, it appeared that the major issue with the reliability department is manpower. The necessary manpower to perform these tasks is imperative to the proper effectiveness of reliability based maintenance. Following is a review of each of the five steps, including impact:

- Verifying and inspecting repaired equipment – once equipment has been sent out and repaired (ie: electric motors), it should be inspected prior to re-installing into the system. In this way, warranty defects can be identified with a reduced chance that production would be interrupted any more than necessary. To this point, the confectionery firm had been testing and verifying repaired equipment. Fifteen minutes worth of testing can save an average of (60 hp motor) 4-6 hours installation and removal for re-work. Assuming a 95% success rate for repaired equipment:  $1/20$  repairs fail;  $20 * 0.15$  hours = 3 hours testing time. Results in a time savings of an average of 2 hours per twenty repaired electric motors.
- Measuring the effectiveness of maintenance programs – Can improve overall maintenance effectiveness by 10%. So, for each maintenance man, whose effective time is 2000 hours per year ( $50$  wks \*  $(40\text{hrs/wk})$ ), performing 50% scheduled maintenance, 100 hours may be saved.



- Vibration Analysis programs – The purpose of a vibration analysis program is to track the condition of critical equipment. Should, for instance, vibration analysis detect the beginning of bearing failure, the equipment can then be scheduled for minor bearing replacement. On the other hand, should the equipment be allowed to operate to failure, such as in the case of the glycol pump, major repair may be required that may also interrupt production. For example, minor bearing replacement on the glycol pump, including bearings (not the seal) would be around \$450. However, as the pump has failed, assuming only machining is required, and not a new impeller, repair would be approximately \$1,150. This represents a difference of \$700. A vibration program would require (based upon quarterly readings) ten minutes per reading, or 40 minutes per year. Over 40% of all motor failures are due to bearings. Applied to 910 motors with a mechanical failure rate of 5% equals 45 motor failures per year.  $910 * 1 \text{ hr per motor per year} = 910 \text{ hours} * \$25 \text{ per hour} = \$22,750 \text{ investment}$ . Assuming an approximate savings of \$700 per motor = \$31,500 saved. This yields an 8.7 month payback.
- Performing root cause analysis of equipment failures – in one primary example, six process motors, UIC-ERC was informed that the average life expectancy of the motors, for the four years they have been operating on variable frequency drives, has been one year. The process motors consist of one 300 hp, 900 RPM, and five 200 hp, 900 RPM motors. The motors are

being run through a four hour cycle with 54% at 140 Hz (2,065 RPM), 23% at 95 Hz (1,401 RPM), and 23% at 60 Hz (885 RPM). The voltage above 60 Hz was a constant 480 VAC. Motor repair on these motors would cost approximately \$3,000 per 200 hp and \$3,250 for the 300 hp equaling a cost of \$18,250 per year in motor repair. For the scope of the project, data was collected on one motor for four hours, plus two hours setup time. With the follow-up analysis, the study took approximately eight hours. Based upon the resulting data, two immediately observable opportunities occur, as well as a secondary issue:

- The first opportunity is that the Volts / Hertz Ratio (V/f) is poor for this VFD application. The V/f on a motor and drive application is normally set up so that the motor and frequency equal 480 V and 60 Hz (7.67V/Hz) or 230 V and 60 Hz (3.83 V/Hz). In an application where the maximum speed will be achieved, this is an appropriate ratio. However, at 480 V, once the 60 Hz point is passed, then the motor continues to increase in speed at reduced voltage. This has two basic issues: 1) the motor acts as if it is undervoltage and will overheat, and 2) the torque curve drops off rapidly past 60 Hz (approximately by the square of the speed). In both cases, damage occurs to the motor windings and insulation system. In the case of the process motors, the motors are set up for a 7.67 V/f ratio that is not used below 60 Hz, but the motors vary from 60 to 140 Hz at 480V.

Option 1 requires contacting the motor manufacturer to see if the V/f range can be changed and the motors rewired / reconnected for 230 V/60Hz then set the V/f to 3.83. In this least cost approach, the motors may still be used, assuming the manufacturer's approval. However, several issues, including rotor inertia and deep rotor bar, as well as reflective wave phenomenon may continue.

- The second opportunity requires the retrofit of the existing motors with 1800 RPM motors. As higher speed motors tend to be more efficient and the motors operate primarily above 900 RPM with only limited overspeed with 1800 RPM motors (285 RPM, 20 Hz) versus the present 1180 RPM, 80 Hz, difference with 900 RPM motors, this retrofit would be more beneficial and more reliable. The replacement cost would be approximately \$9,000 per motor. With reliability improvements, the total payback would be 3.5 years with maintenance savings alone.
- The final issue with the reliability of the process motors is that they are being overloaded approximately 30% of their operating time by an average of 13.4%. This condition will also cause the motor to overheat and the windings and grease to fail early. The overload may be due to the extended speed condition that it is was subjected to. It can be assumed that this issue will be resolved with either of the preceding recommendations.

- With an established reliability program which is able to perform root cause analysis, this type of problem can be avoided. In this case, with an approximate savings of \$45,750 in repairs over three years.

### ***Power Plant Survey***

The University of Illinois at Chicago Energy Resources Center (UIC-ERC) was contracted by Dreisilker Electric Motors, Inc. to develop and provide a motor management database and recommendations for the care and maintenance of electric motors at Southern Energy's Stateline Power Plant. Personnel provided to perform these tasks were (Figure 1, left to right: Howard W. Penrose, Project Manager; Mike Rosenberg, Research Engineer; Christine Walker, Graduate Student/ Research Assistant; Rob Miller, Undergraduate Industrial Engineer; and, not in picture, David Balderas, Research Architect; and, Norm Evison, Dreisilker Electric Motors, Inc.).

**Figure 2: Data Collection Team**



Data was collected using standard data collection sheets (Penrose, 1998) and included electric motors found in outer buildings, boilers 3&4, and support motors for generators 3&4. Information provided by Stateline personnel included a listing of equipment from the powerplant's Motor Control Center (MCC) and general run of the plant in order to find and attempt to identify equipment. It was generally found that the MCC listing was largely inaccurate and that most equipment was difficult to identify due to a lack of markings. In order to work with this situation, best guesses were required. Due to the age of the plant, and the fact that generator locations 1&2 were missing, there was a large number of

electric motors which were not in operation, but were still connected to power or mounted to their original base but not to operating equipment.

Older electric motors were found to be Design A or Design C (for conveyors), with the remainder being Design B, with a few Direct Current and Single Phase electric motors. Standard voltages, for these electric motors, found throughout the plant, were 480 VAC, 60 Hz, and 4,160 VAC, 60 Hz. A majority of the loads were centrifugal pumps and fans, coal conveyors, and crushers.

#### Electric Motor Energy Recommendations

The survey identified a total of 366 electric motors with 328 in-service and 38 spare electric motors.

Of the in-service electric motors, 315 were Design B, 12 Design C, and 1 Design D. The Design B motors are primarily used with fans, pumps, and air compressors. Twelve of the motors were Design C used primarily for coal conveyors, and one motor was a Design D hopper motor.

Of particular importance was the use of Design C electric motors for the incline coal conveyors. This is because of the particular torque requirements for the startup and movement of the conveyors loaded with coal. The Design C motor is excellent for this type of application because of the high start-up, pull-up, and break-down torques. If a Design B motor were to be used in place of a Design C

motor, it would more than likely stall during the pull-up torque portion of the torque curve. Such a problem may be considered for the failure of a new Design B motor accidentally installed in place of a Design C motor.

**Figure: Results of Mis-Application**

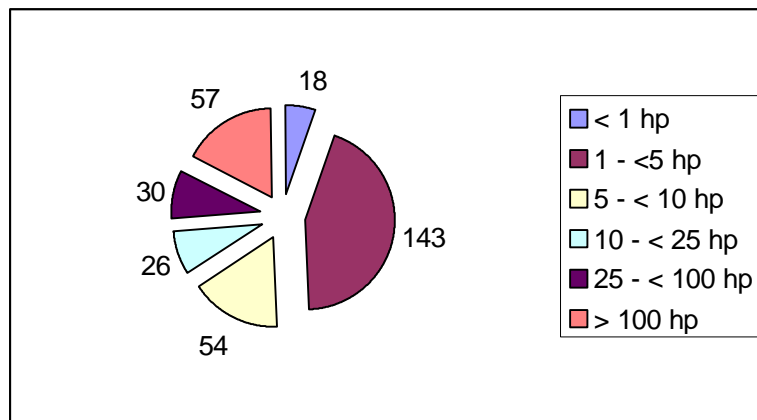

**Figure: Design C Motor**



In this case (the F-12 conveyor motor) the nameplate on the Design C motor was missing and may have contributed to the accidental application of a Design B electric motor. As a result, the electric motor was misapplied and failed during operation. The result of a conveyor motor failure may include shutdown of one generating unit, depending on the amount of time the conveyor is inoperable.

**Figure: Electric Motor Population**





In all electric motor retrofit or repair versus replace decision making processes, the application must be considered. In the case of Stateline Power Plant, most of the electric motors were heavily built for reliability as well as many being produced as dust or explosion-proof. The ever present coal dust creates such an atmosphere as requiring explosion proof electric motors. This means that electric motors directly exposed to coal dust areas should be explosion proof to avoid the possibility of catastrophic explosion or fire due to electric motor failures (shorts, grounds, fire).

Other considerations for retrofitting or repair versus replace decisions for electric motors at Stateline include:

- As many of the larger electric motors are original frame or U-frame, base retrofits or modifications have to be considered as an additional cost.
- Shaft couplings may have to be changed out to fit newer electric motors, due to different shaft sizes.
- Heaters, fuses, starters, and wiring must be properly sized to work with appropriate electric motors.
- Possibility of variable frequency drive applications for fans, pumps, and air compressors.

- Operating / full load speed differences between newer energy efficient electric motors and older electric motors. In many cases, the energy efficient electric motor has a greater full load speed than an older electric motor. If this occurs in a variable torque application, such as a fan or pump, the horsepower requirements for that application may increase and the resulting piping or ventilation piping/ductwork restriction increase will reduce the overall system efficiency.

Through the use of MotorMaster Plus, retrofit and repair versus replace decisions can be analyzed from an energy standpoint. For the purpose of this study, the following information was used: Estimated energy costs, \$0.025/kWh and \$10/kW demand; 35% discount factor on General Electric motors; and a five year simple payback maximum. As a result, fifteen of the in-service electric motors were found to be excellent retrofit candidates, with a use reduction of 68,705 kWh and demand reduction of 8.2kW for a 37% after-tax Return on Investment (ROI) and 1.7 Benefit to Cost (BC) ratio. In addition, 51 electric motors were found to be excellent Replace instead of Repair candidates with a use reduction of 197,254 kWh and 23.5 kW demand reduction ending with a 92.9% ROI and 3.2 BC ratio.

Electric Motor Maintenance and Reliability

Causes for electric motor failure are fairly wide and varied. The primary causes, however, tend to be bearings and shorted / grounded windings. The primary cause for either of these failures is contamination with the secondary cause being improper maintenance and the third, improper application. The best way to avoid unexpected electric motor and equipment failures is through a properly scheduled and maintained maintenance and reliability program.

Maintenance can be defined, within this report, as a scheduled system for maintaining equipment in operating condition through the application of measures and recommendations from manufacturers and equipment history. Reliability is the method of applying tests and equipment history to the maintenance or improvement of systems to decrease the possibility of equipment failure.

Within these two definitions, there are different levels of maintenance systems:

- ✓ Reactive Maintenance - Is the practice of allowing equipment to operate until failure. In this type of maintenance costs can increase dramatically on critical operating equipment and inventory of spare parts.
- ✓ Preventive Maintenance – The practice of performing basic maintenance such as greasing or cleaning, based upon manufacturers recommendations or

company maintenance history, in order to maintain, or extend, the expected life of the equipment.

- ✓ Predictive Maintenance – A reliability measure used to detect and track potential equipment failure. Measurements must be measurable and repeatable. Requires periodic testing of the equipment to first detect then analysis to determine the expected remaining life of the equipment. Allows the ability to determine when to schedule corrective maintenance and maximum use of equipment before failure. Additional savings are found in performing minor corrective maintenance versus the major repair that would accompany catastrophic failure.
- ✓ Corrective Maintenance – Is the measure of repairing equipment that has failed. This can be as simple as bearing replacement to a complete overhaul of the electric motor. Many companies do not provide information with the electric motor to be repaired (repair specification), however, this can be of great importance along with receiving a repair report.
- ✓ Proactive Maintenance – Is the measure of investigating cause of failure (root cause analysis). This can be of importance to systems which are seeing repeated failure over a period of time. For instance, an electric motor that is failing every 12 – 14 months should be investigated to determine the cause of failure in order to extend the operating life of the system. This style of

maintenance also includes taking information before repair and obtaining acceptance and baseline information following equipment repair.

#### Preventive Maintenance Recommendations

Because of the particular operating environment at the Stateline Power plant, a strict preventive maintenance program should be implemented on the rotating equipment and related equipment. Such a program should include the following:

- Electrical Distribution: Semi-Annual cleaning of the insides of MCC's and other electrical cabinets including switchgear. This can be performed with the equipment locked and tagged out using explosion / dust proof vacuum cleaners with static resistant nozzles. Through the removal of dust and other foreign matter there will be a reduction in the chance for fire, should the equipment fail, or the possibility of the contaminants effecting the operation of the motor controls and electrical systems.
- Visual Inspection: Of electrical equipment must be performed to verify the correct fuse and heater sizing for O/L protection. Generally, a visual inspection will also identify overheating found by discoloration of equipment components. Look for dry and cracked cabling, "blued" metal connections, deteriorating ground connections, and other defects.

- Visual Inspection: of the electric motor must be performed semi-annually, as well. In particular to identify overheating, dirt, and other issues. For instance, one of the boiler blowers on the #3 boiler was packed with dirt, reducing its effectiveness and the life of the equipment.
- Greasing: Greasing of greaseable bearings on the electric motor and related equipment should be performed as identified in. Use of the same grease is required each time due to the possibility of grease incompatibility.
- Testing: A general megger test may be performed to determine the insulation resistance to ground for reference, not as a Predictive Maintenance measure.
- Inspect: During visual motor inspections and greasing, the condition of the belt or coupling should be determined, including the condition of the alignment and belt tension. One cause of maintenance related failure is the misalignment or mistensioning of belts or couplings.

**Figure: Dirty Blower**



Predictive Maintenance Recommendations

Several basic measures may be taken in order to establish a complete picture of the motor systems from a PdM standpoint to cover the electrical and mechanical components of the motor system. These include, at a minimum:

- Vibration Analysis – Used to evaluate the mechanical condition of rotating machinery. Using the analysis portion of vibration testing defects in

equipment can be detected including: bearings, rotor bars, misalignment, belt mistensioning, unbalance, etc. (see Attachment 8). Vibration analysis should be performed on critical rotating equipment and hard to access equipment at least once per quarter for the power plant. Key items that must be addressed include: ensure equipment is at least 50% loaded; a minimum of five points must be collected on each electric motor (horizontal, vertical, axial – opposite drive end; horizontal and vertical – drive end) as well as on the driven equipment; and the readings should include velocity, acceleration, mils, and at least one g/SE reading on each bearing. On critical applications, depending on the severity of production impact should the equipment fail, real time sensors and equipment may be installed with alarms.

- Infrared Thermography – Compares ambient (background) temperature with component temperatures. The background and component temperatures should be the same, or corrective action may have to be performed. Infrared Analysis is used to detect: system unbalances, loose connections, bad contacts, and other similar defects in the electrical equipment. This type of test must be performed with the connections and components exposed and loaded at least 50% for accurate readings.
- Motor Circuit Analysis – Through the use of inductance, milli-ohm, impedance, capacitance, and resistance to ground readings, early detection of insulation defects and other high resistance / impedance connections can be



detected. With the use of modern test equipment early detection of short circuits, grounds, and other circuit defects can be accomplished allowing for planned repair versus catastrophic failure. Motor Circuit Analysis can also be used to detect open or broken rotor bars.

**Figure: Causes of Motor Failure**

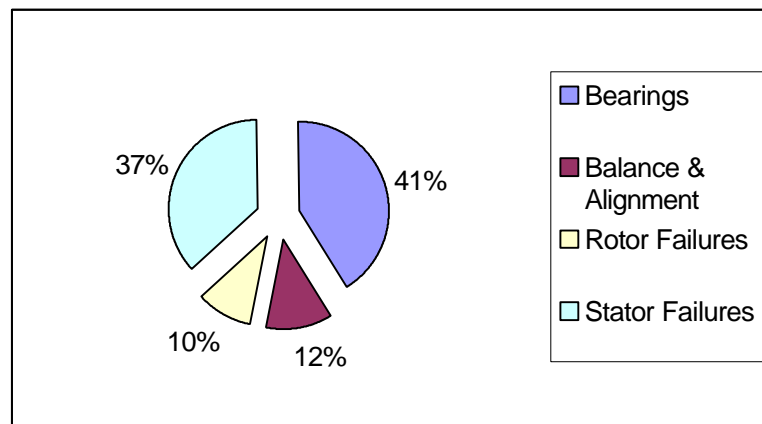

Each critical motor and motor related circuit should be subject to a quarterly inspection including:

- ✓ Vibration Analysis – Using a good data collector and analysis software package.
- ✓ Infrared Analysis – Utilizing a motion type infrared camera and analysis software package.
- ✓ Motor Circuit Analysis – Using a hand-held data collector and analysis software package.

It must be determined whether these programs will be performed in-house or by an outside source. If manpower is an issue, by combining outsourcing with permanently mounted equipment, manpower requirements can be kept to a reasonable level. In most cases, capturing a potential catastrophic failure will pay for the entire program when considering labor, repair savings, and equipment downtime and production impact. Through a combination of these three PdM tests, close to 100% of predictable failure may be detected. Exceptions to this include dynamic failures (lighting strikes, single phasing, load surges, environmental issues such as fire or other sudden contamination, etc.) and maintenance errors (such as misalignment or improper / broken belts between readings). In order to avoid dynamic failure, electronic protection will improve the electric motor's survivability and with maintenance errors, a means of checks and balances will assist (Reliability).

#### Corrective Maintenance

Once equipment has failed, or has been predicted to fail (PdM), it must then be repaired and / or other corrections must be made to related equipment. When this occurs a plan must be in place to reduce potential downtime and unnecessary costs. In addition, a practice of verifying cause of failure and testing repaired equipment should be in place.

Plan features should include:

- Pre-made decisions, such as: Replacing the motor with an energy efficient electric motor from spares or local repair shop inventory; or, repairing electric motor due to high turnaround times and costs for new equipment. It should be noted that the long term costs of operating a poorly repaired electric motor will outweigh a slightly higher repair or replacement cost. MotorMaster Plus can assist in these pre-made decisions in cooperation with an electric motor repair and new motor vendor.
- Pre-made agreements: Setting up an agreement with a high quality electric motor repair / new motor vendor will allow for improved costs, faster turn-arounds, improved service and response, and a mutual understanding of needs and requirements. This should include special services including management of electric motor spares and special inventory incentives. Also, partnerships allow for improved control of repairs and replacements that cannot be achieved through “blind” services.
- Spares Inventory: An up-to-date spares inventory for critical equipment may be required. By ensuring that spares inventory reflects actual requirements, inventory costs and valuable space may be saved. For additional information see the SPARES section of this report.

- Specifications: Communicate requirements including minimum standards for repair, grease types used, acceptable testing limits, and reporting requirements. Visit the repair center to ensure that it is capable of performing the requested tasks, and include the ability to witness any tests performed on the electric motor. A requirement for a quality control program is recommended (such as ISO 9000) as a minimum, along with the availability of the program for inspection and auditing upon reasonable request. Electric motor repair specifications should include temperature limits for winding removal and preferences for mechanical stripping to avoid stator core damage and mechanical twisting / deformation due to higher temperatures, resulting in lower efficiency, poor air-gap, reduced reliability, and soft foot conditions.
- Alignment and Belt Tensioning: When re-installing electric motors, for both belt driven and direct drive equipment, the first step must be soft foot testing due to changes in the stator frame and base. Soft foot, in either case, will result in unusual strains on the stator housing reducing the reliability of the electric motor. Use of laser alignment equipment and known thermal growth requirements for each system is necessary. Belt tensioning equipment is also necessary for belted equipment with known standards.
- Reliability: Testing (Vibration, Infrared, and Circuit Analysis) should be performed following corrective maintenance in order to verify the repair and set baseline measurements for PdM. This can also be considered the

“acceptance” stage, in particular for equipment that will end up as spare for any length of time so that any defects are caught during the warranty period.

#### Proactive Maintenance Recommendations

A process for determining the root cause of failure for equipment must be established. In a high instance of cases the failure is not the cause but is the result of some other system defect. For instance, a combination of a process overload and improperly sized circuit protection may cause the electric motor to burn up. If the cause is not determined (the system overload and circuit protection sizing) the next electric motor, or the repaired motor, will undergo the same cause of failure.

Methods for performing proactive maintenance include:

- Tracking motor repairs and causes provided by the motor repair shop in a MotorMaster Plus database so that when PdM or Corrective Maintenance identifies a motor failure, a history is available to “red flag” the electric motor for a complete analysis.
- An in-depth investigation of all electric motor repairs including a root cause analysis report provided by the electric motor repair shop.
- Utilizing the parts ordering department (or purchasing) to identify consistent requirements for the same parts for equipment. This may be performed

through a database and requisition forms. If possible, the use of a Computerized Maintenance and Management System (CMMS) would be warranted.

When performing a root cause analysis, a systems perspective, including both electrical and mechanical, must be considered. In many cases, the cause of a mechanical problem may be caused by an electrical defect or vice-versa.

#### Spare Equipment Considerations

While performing the evaluation and survey of the electric motors at Stateline, a review of the on-site spare inventory was performed. This particular subject requires attention as a fairly significant number of “spares” stored at the power plant do not match other electric motors and a number of the remaining “good” spares are stored incorrectly.

**Table: Spare Motor Status**

<u>Motor Number</u>	<b>Status</b>	<b>Recommendation</b>
321	Spare, matches motor 326	Test spare and store in spare motor area
322	Does not match active motors	Discard
314	Spare, matches motors 38 & 39	Test spare and store in spare motor area
315	Spare, matches motor 163	Test spare and store in spare motor area
316	Bad, Rusty shaft and does not turn	Discard
313	Same as spare 314, rusty	Discard
323/324	Spare, compatible with 11 motors	Test and store in spare motor area
160	Does not match active motors	Discard
128-137	Soot blower spares, poor storage and condition	Recondition, a number may have to be combined into one motor.
225	Does not match active motors	Discard
59	Does not match active motors	Discard
26	Does not match active motors	Discard
198	Does not match active motors	Discard
25	Does not match active motors	Discard
224	Does not match active motors	Discard
325	Does not match active motors	Discard
226	Does not match active motors	Discard
229	Does not match active motors	Discard
230	Does not match active motors	Discard
231	Does not match active motors	Discard
232	Does not match active motors	Discard
233	Does not match active motors	Discard
317	Does not match active motors	Discard
319	Does not match active motors	Discard
199	Does not match active motors	Discard
234	Spare, ok but frame does not match 195	Discard and replace spare
318	Does not match active motors	Discard
317	Does not match active motors	Discard

Most of the spare electric motors are stored in the Generator Bays 1&2. In general, the spare motors are in poor condition and will require attention. As can be seen in the Table, a majority of the electric motors being held as “spares” do not match any of the electric motors collected during the course of the survey. A number of the larger electric motors (greater than 100 horsepower) may be rebuilt and sold as rebuilt. The smaller electric motors (less than 100 horsepower) should

be scrapped due to their general condition. Many of the remaining spares do not count as energy efficient and should be considered for scrap. Due to the general nature of the motors, other power plants may be interested in obtaining the larger spare motors that are no longer of use to Stateline.

#### General Comments and Recommendations

Following is a short list of comments for consideration.

- When replacing or inspecting electric motors, ensure that the connection box is secure to the electric motor. Without the connection box in place there is danger to the connections and to the safety of personnel.



**Figure 3: Bad Connection Box**



- ❑ Additional electric motors no longer in service should be disconnected and removed to reduce the danger of accidental injury to equipment or personnel.

**Figure: Motor No Longer In Service**



**Figure: Pump No Longer In Service**



- ❑ Electric motor at top of silo has high vibration and is incorrectly mounted.

**Figure: Silo**



***Commercial / Retail Bakery Assessment***

Wholesale operations and retail sales were the two major subdivisions of the bakery. Wholesale sales accounted for two-thirds of the firm's profits, while retail sales accounted for the remaining third.

The vast majority of wholesale profits were the result of sales of cookies, which accounted for over half of the firm's profits in this area. Nearly all of the cookies produced were purchased by one company which carried the cookies nationwide.

Distribution of the bakery's main profit centers occurred on a nationwide scale. Shipments outside of the Chicago area were made through UPS, for which the business paid the full rate. Within the Chicago metropolitan area, distribution was handled by a third party distributor.

National demand for the cookies was strong and constant. The bakery was unable to keep up with orders and regularly ran one to four days behind in filling orders. Local demand for the cookies was just as strong, with production running behind at the same rate as national customers. Local product for retail product was also strong as the bakery did a brisk business on weekday mornings selling coffee and donuts. Its close proximity to two different train stations made an excellent location to stop before boarding. Additionally, the bakery's line of cakes also sold well, mainly in the afternoons and on Saturdays.

The goals of the bakery's owners were relatively straight forward. They wished to expand the production capacity of the wholesale operation so that they could take advantage of cookie demand. They also wished to expand their wholesale

operation beyond one primary customer to four of five vendors so that their business would be less dependant upon the one customer. It was to be assumed through the study that the demand for the cookies was unlimited, resulting in the conclusion that the only way to increase customer base is to increase production capacity.

Upon the initial visit to the bakery a discussion of the corporate goals and a tour of the bakery presented a number of immediately obvious opportunities. Those initial observations included: broken and discarded machinery on the production floor and storage areas; production workers having difficulty passing each other in the aisle-ways; observed energy consuming equipment; and altered baking schedule based upon materials availability. Based upon those initial observations, it was determined that the following was the order of opportunity:

- Production Improvements
- Energy Use
- Waste Stream

This was further supported upon review of the energy and waste costs incurred by the bakery over one year. As a result, it was determined that a team of five undergraduate industrial engineering students would perform as an Industrial

Engineering Team. The purpose of this team would be to study the processes and determine an optimal approach to improved operations and improved cost per unit of production. The UIC-ERC would review the energy and waste stream opportunities and oversee the IET efforts.

### Energy Conservation Opportunities

A number of energy conservation opportunities were realized throughout the energy, waste stream, and production survey (industrial assessment) performed at the bakery. It was important to realize that the opportunities for energy, waste stream, and production were tied together.

#### Insulate Doors and Windows

One issue identified on the first visit to the bakery was the condition of the basement shipping doors and the windows, the bakery rear door, and the second floor rear office doors. In each case, they are not insulated and contain large air gaps direct to the outside. This became even more significant when, on one visit during a cold day, the second floor office doors blew open during the night and caused the retail area and bakery to freeze. In order to counter the freezing temperatures during the winter months (for the purpose of calculating savings,

only heating degree days were identified for the use of heaters) portable heaters were used. Based upon the heat used by the oven, as well as hot water heating capabilities of the building, a significant reduction in electrical use can be identified by insulating and repairing the doors and windows.

The portable heaters are located in the upper offices, one in the front hallway, and one in the materials storage area in the basement. The total Wattage of all electric heaters is 7.2 kW. Based upon the Heating Days for the Evanston area, a service factor of 60% may be estimated over a seven month period.

**Equation: Eliminate Space Heaters**

$$\begin{aligned}(7.2 \text{ kW} * 0.6) * \$11.13/\text{kW} * 7 \text{ months} &= \$336.57 \text{ Demand Charge Reduction} \\ 30 \text{ weeks} * 6 \text{ days/wk} * 12 \text{ hrs/day} &= 2,160 \text{ hours / year} \\ 2,160 \text{ hrs/yr} * (7.2\text{kW} * 0.6) * \$0.04397/\text{kWh} &= \$410.29 / \text{year} \\ \text{Estimated Savings} &= \$336.57 + \$410.29 = \$746.86\end{aligned}$$

The estimation of insulating and repairing the doors and windows, assuming the work is performed in-house, would be approximately \$6,100 for windows and doors (basement – Home Depot) and insulating materials. Simple payback would be 8.2 years.



### Boiler Maintenance and Trim

Many factors, including environmental considerations, cleanliness, quality of fuel, etc. contribute to the efficient combustion of fuels in boilers. It is therefore necessary to carefully monitor the performance of boilers and tune the air/fuel ratio quite often.

During the interview at the bakery, it was determined that there was no practice of maintaining the boiler at optimum performance. This had the dual effect of additional energy costs and reduced boiler life-cycle. In addition, it was identified that there was no insulation on the piping leaving the boilers to the rest of the building.

The estimated fuel savings for boiler trim would be:

**Equation: Periodic Inspection and Adjustment of Boilers**

$$1.0\% \text{ burned} * 2,302 \text{ therms / year} * 0.03 \text{ possible fuel savings} = 69.06 \\ \text{therms/year}$$

$$69.06 \text{ therms /year} * \$0.27 \text{ /therm} = \$18.65 \text{ / year}$$

There was no significant energy payback through a periodic inspection and adjustment of the two boilers located in the basement level. However, the life and reliability should justify the cost of performing this service at least once per year.

### Uninsulated Steam and Hot Water Piping

A great deal of heat can be lost due to heating caused by uninsulated steam and hot water piping. In the case of the bakery, all of the steam piping is uninsulated as well as the hot water piping (150 ft).

**Table: Uninsulated Steam Piping**

<b>Pipe Outer Diameter</b>	<b>Length of Piping (ft)</b>	<b>Surface Area (ft<sup>2</sup>/ft)</b>
4	2.5	1.178
2.5	3	.785
1	150	.393

With the boiler piping, the steam leaves the boiler at 180 F and the average temperature in the basement area is 78 F. The resulting temperature difference is 102 F and the cost per MMBtu is \$2.70, which results in a base cost of \$0.80/sqft which is the cost per square foot lost at \$1 / MMBtu and 102 F difference (Hicks, 1995, p. 3.520). This is then applied against an estimated efficiency of 72% and the actual cost per MMBtu resulting in an annual loss of \$192.49 per year. Insulation for this steam piping could be purchased at a local hardware store for an investment of \$26 resulting in a simple payback of .14 years (immediate).

**Equation: Cost for Uninsulated Piping**

$$4'' \text{ Pipe: } 1.178 \text{ sqft} * \$0.80/\text{sqft} * 2.5\text{ft} = \$2.35 / \text{year}$$

$$2.5'' \text{ Pipe: } 0.785 \text{ sqft} * \$0.80/\text{sqft} * 3\text{ft} = \$1.88 / \text{year}$$

$$1'' \text{ Pipe: } 0.393 \text{ sqft} * \$0.80 / \text{sqft} * 150 \text{ ft} = \$47.10 / \text{year}$$

$$\$51.33 * (\$2.70/0.72) = \$192.49 / \text{year}$$

The water heater was producing 110 F water in a basement area that maintained 72 F which resulted in a difference of 38 F. The base cost is \$0.40 / sqft on 150 feet of one inch diameter piping (0.393 sqft). When compared to \$2.70 / MMBtu at an estimated 72% efficiency (Hicks, 1995, p. 3.522) the losses per year show as \$88.43. Pipe insulation is the same type as for the boiler (\$26 for the 150 feet) resulting in a simple payback of 0.29 years.

In the case of both the boiler and water heater, the heat loss from the piping added to the basement heat load. This impacted the freezers and compressors located in the immediate area by increasing the amount of energy required to maintain product and ingredient temperatures as well as increasing the loads on the compressors resulting in decreased reliability.

#### Freezer and Compressor Opportunities

There were three basic types of freezers located at the bakery. The first type was older wooden freezers with large heavy doors. There were two located in the basement level and one located on the rear porch area. The second type was large aluminum type moveable freezers located in the basement and bakery area. The third is made up of the glass-front types used in the retail area of the bakery.

There were multiple opportunities with the freezers and compressors. One opportunity included the replacement of gaskets on the older wooden freezers, the other opportunity was identified through a general maintenance program on the compressors themselves, which were located in the basement.

In several cases, gaskets have failed on the Federal Freezer doors in the production area. The temperature maintained by the Federal Freezer was 32 F with the average room temperature (outside temperature independent) of 85 F. The average resulting opening was .25 inches by 104 inches with four doors missing gaskets and four with severely damaged gaskets. Total exposed area was 13 sqft. The result was a 0.23 kW demand and, based upon 8,760 hrs / year, a 2,015 kWh/year demand resulting in an annual energy loss of \$119.62 / year. Gasket material could be purchased from a local hardware store for \$12.95 / 12 ft. (69.4ft = \$77.70) which provided a simple payback of .65 years.

**Equation: Heat Flow Costs (ASHRAE, 1997, p. 120)**

$$\text{Heat Loss} = UADt$$

$$1.13 \text{ Btu}/(\text{h} \cdot \text{F} \cdot \text{sqft}) * 13 \text{ sqft} * (85 - 32 \text{ F}) = 779 \text{ Btu} / \text{hr}$$

$$779 \text{ Btu} / \text{hr} * .00029 \text{ kW} / (\text{Btu}/\text{hr}) = 0.23 \text{ kW demand}$$

$$0.23 * 8760 = 2,015 \text{ kWh}$$

$$(.23 \text{ kW} * 12 \text{ mo.'s} * \$11.24 \text{ demand}) + (2,015 \text{ kWh} * \$0.04397/\text{kWh}) = \\ \$119.62/\text{year}$$

Considering the compressors, a program for changing the lubricant periodically could save energy from compressor usage. “Manufacturers of synthetic lubricants claim from actual field experience and energy savings of 10-20% of the energy normally lost... with the use of their product.” (Rutgers, 1995, p.29) Following was the potential savings from the use of synthetic lubricants in the compressors (check manufacturer’s requirements with refrigerant).

**Equation: Lubrication Savings**

$$6.04 \text{ kW} * (1-0.8\text{eff}) * 0.75 \text{ load factor} * 0.1 \text{ improvement} = 0.1 \text{ kW/mo.}$$

$$1.2 \text{ kW demand / year} * \$11.24 \text{ avg demand} = \$13.49 / \text{year}$$

$$\sim 2,890 \text{ hrs / year} * 0.1 \text{ kW} * \$0.04397 / \text{kWh} = \$12.71 / \text{year}$$

$$\text{Total Annual Savings} = \$13.49 + \$12.71 = \$26.20 / \text{year}$$

Synthetic lubricants for refrigeration compressors can be quite expensive (\$5/qt). An estimate of the volume required to lubricate the compressors suggests 1.5 gallons for lubrication of all refrigeration compressors (\$30) with a 1.2 year payback. As there has not been a lubrication program for the compressors, it is recommended that this is performed once per year along with an inspection. The result was both an energy savings and a potential increase in equipment reliability. Also, four broken refrigeration compressors were removed.

#### Packaging Machine Usage

It was determined that the packaging machine was left on for almost twice its actual required usage. The energy savings potential, in this case, was to turn off the packaging machine when not in use.

The packaging machine is run approximately seven hours per week. Of this time, approximately 3.5 hours is idle.

#### **Equation: Packaging Machine Savings**

$$3.5 \text{ hrs/wk} * 52 \text{ wks} * 3.5 \text{ kW} * \$0.04397/\text{kWh} = \$28.00/\text{year}$$

As there is no expense in implementing this program, the payback is immediate.

#### Building Heat Loss – Windows and Doors

The bakery had a number of issues with window and rear door/building insulation systems. Prior to considerations for air conditioning these insulation issues would have to be addressed.

There was 476.9 sqft of single pane windows and 63.2 sqft of outer, uninsulated doors at the bakery including the basement, first, and second floors. Average upper level temperature was 72 F, first floor was 85 F, and basement (near doors)

75 F. The average winter temperature in 1998 was 44 F over seven months, and summer, 72 F over five months.

**Equation: Building Heat Loss (Winter - Seven Months)**

$$1.13 \text{ Btu}/(\text{h}\cdot\text{F}\cdot\text{sqft}) * 42 \text{ sqft} * (75-44 \text{ F}) = 1,471.3 \text{ Btu/hr (basement)}$$

$$1.13 \text{ Btu}/(\text{h}\cdot\text{F}\cdot\text{sqft}) * 414.9 \text{ sqft} * (85-44 \text{ F}) = 19,222.3 \text{ Btu/hr (basement)}$$

$$1.13 \text{ Btu}/(\text{h}\cdot\text{F}\cdot\text{sqft}) * 81.4 \text{ sqft} * (72-44 \text{ F}) = 2,575.5 \text{ Btu/hr (basement)}$$

$$\text{Total heat lost over the heating period} = 23,269 \text{ Btu/hr} * 5,112 \text{ hrs} = 119 \text{ MMBtu}$$

**Equation: Building Heat Gain (Summer - Five Months)**

$$1.13 \text{ Btu}/(\text{h}\cdot\text{F}\cdot\text{sqft}) * 42 \text{ sqft} * (75-72 \text{ F}) = 142.4 \text{ Btu/hr (basement)}$$

$$1.13 \text{ Btu}/(\text{h}\cdot\text{F}\cdot\text{sqft}) * 414.9 \text{ sqft} * (85-72 \text{ F}) = 6,090.5 \text{ Btu/hr (basement)}$$

$$1.13 \text{ Btu}/(\text{h}\cdot\text{F}\cdot\text{sqft}) * 81.4 \text{ sqft} * (72-72 \text{ F}) = 0 \text{ Btu/hr (basement)}$$

$$\text{Total heat lost over the heating period} = 6,233 \text{ Btu/hr} * 3,648 \text{ hrs} = 22.7 \text{ MMBtu}$$

At an estimated \$125 per window and \$1,200 per door, the total cost to improve the insulation at the bakery (not including caulking and building insulation) would be \$6,100 if performed in-house. The result was a Loss/Gain reduction of (based upon a  $U$  value of 0.45): Winter – 14,003 Btu/hr which is a reduction of 71.6 MMBtu heat loss; and, Summer – 3,749 Btu/hr which is a reduction of 13.7 MMBtu of heat gained during the cooling season. This resulted in a winter heating savings of \$193.32 and a summer cooling savings of 1.1 kW demand and 4,012.9 kWh which resulted in an overall savings of \$239 against the additional energy required to operate an air conditioner.

### Lighting Retrofit

A lighting retrofit survey was performed as part of the energy survey. As most of the lighting located at the bakery is older T12 and incandescent, a very large opportunity for energy savings was found. The lighting retrofit costs assumed that the work would be performed in-house and would not require sub-contracted work. The result of an overall lighting retrofit would result in a 3.59 kW demand reduction and 59,953 kWh usage reduction over the period of one year. This resulted in an annual energy savings of \$3,466.76 per year with a retrofit cost of \$4,699 resulting in a simple payback of 1.4 years.

### Operations and Production Improvements

A very significant opportunity at the bakery was the operations and production improvements identified through a UIC Energy Resources Center / Industrial Engineering Senior Design Project. This group was identified as the IET for this project.

The task of the IET was to identify process improvements at the bakery through the use of simulation software and an industrial engineering approach. The software selected was ProModel simulation software which assisted the IET in identifying the following opportunities:



- Create a Master Production Schedule (MPS)
- Repair the oven
- Repair the cookie cutter
- Repair the steam kettle and add a second unit online
- Rearrange the work areas, consolidating cake operations and creating wider and clear travel aisles. Include consolidating equipment at each station to reduce waste travel times.

The result of implementing these tasks was:

- Increase cookie production by 41%
- Decrease waste by 6%
- Reduce labor costs (improve labor effectiveness) by 3%

Create a Master Production Schedule (MPS)

One issue identified during the IET study was the performance of product scheduling to meet customer demand. The mixer-operator would check the cookie storage freezer at the beginning of each day, determine the lowest quantity of product, then check ingredients. Based upon these two factors, the type of

cookie produced would be determined. In addition, conflicts between retail cake and other products and the cookies would occur.

The IET determined the best method to approach a system that would more readily meet customer demand, reduce production equipment conflicts, and allow ingredients to be stocked per production requirements, would be to implement a Master Production Schedule (MPS). In order to implement the MPS, some additional work would be required by a production scheduler. This additional work would include forecasting cookie, cake, and other product requirements over a period of time. The schedule can then be used to determine when and how many of a product will be produced and allow for employee scheduling to reduce conflicts. Forecasting will require a review of past purchasing and a knowledge of customer requirements in order to estimate future production needs.

#### Repair Oven

One of the two primary bottlenecks to all bakery production was damage to the baking oven. One of the five production racks was damaged in a way that it was not usable for production. Based upon the simulation modeling performed, this actually reduces production (when including processes following the oven) by 25%. According to the IET team interview with the owners, the repair would require one day and approximately \$300. Through a study of the processes

following the oven and through the implementation of an MPS, it was determined that the repair and resulting increase in production would not generate significant additional bottlenecks.

#### Repair Cookie Cutter

The second major bottleneck was the condition of the cookie cutter. The cookie cutter was being repaired at least once per day of operation. Upon review of the repairs that had been taking place, it was determined that the equipment was being repaired, literally, with duct tape. When the cookie cutter failed during operation, it would remain inoperable for at least 30 minutes. The main cause of failure had been the use of standard bolts in metric threads for the machine hopper / cutter assembly. Repairing the machine would require: opening up the bolt holes and drilling and re-tapping the threads for the larger size bolts. This would require no more than four hours and \$25 in materials.

#### Steam Kettles

The one existing steam kettle, which was the preferred method for melting chocolate and caramel for production cookies, is often not operational. As a result, a microwave was often used, which was shared with the retail baking group (cakes, etc.). This created a bottleneck for all production and retail baking.

The most probable cause for failure of the steam kettle was the steam trap (\$150). It was recommended that the steam trap be replaced and that a second steam kettle, which was stored by the bakery, was to be installed to increase the production of cookies.

#### Rearranging Work Stations

One observation made by the IET during each visit was the lost motion time during operations. Workers were required to leave their workstations to obtain equipment and workstations were designed so that personnel had to cross paths with each other constantly. Through an improved layout, not only can these instances be avoided, but production throughput can be increased. Additionally, by redesigning work stations to include commonly used equipment, for that station, time and motion studies were reduced (minutes lost per cake for a worker to leave the workstation, find tools, and return).

#### Impact of Production and Reliability Improvements

The resulting measurable impact of implementing the IET recommendations will be the process flow improvement over 41% for cookie production. This allowed for the elimination of back log for the level of demand present during the study and also for the added capacity for additional customers and demand.

Increased production would mean an increase from an average of 3,000 pounds of cookies per week to the capability of handling 4,230 pounds per week, or an increase from 156,000 lbs / yr (78 tons) to 219,960 lbs/yr (110 tons). As cookies made up 1/3 of the total production in-plant, the energy cost per ton of cookies per year was \$66.69 electric / ton of cookies and \$17.95 gas / ton of cookies. The new energy cost would be \$47.29 electric / ton of cookies and \$12.73 gas/ton of cookies. This results in a savings of \$24.62 / ton of cookies in energy costs alone. This was not an energy reduction, but an energy effectiveness improvement. The same amount of energy would be used in either level of production, with reliability and production improvements implemented. The total effectiveness (payback for production and reliability improvements, based upon energy alone) would be an annual improvement of \$2,708.20 per year which would result in an immediate payback.

#### Waste Stream Opportunities

The bakery performed several basic waste stream recovery programs. These included:

- Cardboard recycling
- Rework / regrinding materials / production waste
- Providing dated materials to soup kitchens

Several other opportunities also presented themselves, including:

- ❑ Recycling plastic containers
- ❑ Recycling “dropped” product
- ❑ Dispose of broken equipment and unused materials

A specific method for recycling the landfilled plastic containers do not fit within the scope of the project. However, plastics appear to make up a significant portion of one of the containers of garbage stored at the back of the building.

Dropped product, identified during several IET visits, occurs when cookies fall from the cookie trays coming out of the oven and when rejected during packaging. It was observed that over a dozen cookies within 60 seconds were disposed of into a waste basket during the packaging operation. It was also observed that several cookies per sheet were lost when the cookies have been removed from the oven. This is coupled with an observation that employees work to “appear busy.” Meaning, it is not unusual to see employees “rushing around.” On the surface it appears that the employees were hustling, however, upon close observation, the rushing was due to poorly placed equipment and processes.

Another key opportunity is the reduction of lost space within the bakery due to obsolete storage and broken equipment. For this we will assume \$10 / sqft per year based upon an estimation of the owners:

- ❑ Wasted pans in the basement:  $60\text{sqft} * \$10/\text{sqft} = \$600/\text{year}$
- ❑ Broken refrigeration unit / blocked area:  $100\text{sqft} * \$10/\text{sqft} = \$1,000 / \text{year}$
- ❑ Wasted space due to walled in old bathroom in basement:  $64\text{sqft} * \$10/\text{sqft} = \$640 / \text{year}$
- ❑ Enclosed basement area:  $60\text{sqft} * \$10/\text{sqft} = \$600 / \text{year}$

### ***Grain and Corn Miller Survey***

Upon the initial visit of the UIC-ERC and IL DCCA, a large number of opportunities presented themselves. Based upon the types of energies utilized at the miller (combined heat and power, steam, compressed air, process heat, and electric motors) and the overall size of the plant, it was determined that the project would require two phases. In the first phase, a group of engineers from UIC-ERC and IL DCCA would perform a basic walk-through and determine a focus for a second phase. In the second phase, UIC-ERC would focus on several specific areas identified in the first phase.

During the first phase, plant-wide steam and lighting audits were performed. A complete walk-through of the plant was performed identifying potential

opportunities in the starch and gluten production areas, as well as the distillery. It was determined that a portion of the distillery location would be studied as well as the gas dryer efficiencies and the compressed air system of the starch and gluten packaging plant.

During the first phase, plant-wide steam and lighting audit were performed. A complete walk-through of the plant was performed identifying potential opportunities in the starch and gluten production areas, as well as the distillery. It was determined that a portion of the distillery location would be studied as well as the gas dryer efficiencies and the compressed air system of the starch and gluten packaging plant.

During the second phase, one week was spent within the plant performing the following:

- ❑ A MotorMaster Plus electric motor survey and audit of the fungi and cooking plant, including data collection of several electric motors.
- ❑ Compressed air leak study of the fungi and cooking plant.
- ❑ Review of the compressed air system and opportunities in the starch and gluten packaging plant.
- ❑ Steam leak study of the fungi and cooking plant.



- ❑ Efficiency of the gas dryers in the distillery.
- ❑ Pump seal failures.

### Electric Motor System Recommendations

Once the miller's MotorMaster Plus database was developed for the fungi and cooking plant, the UIC-ERC began to review the existing motor system and generate several scenarios. As the miller had expressed an interest in Toshiba and Teco electric motors, two sets of scenarios were developed:

1. Repair versus Replace Scenarios
  - 1.1. Toshiba and Teco Motors Only
  - 1.2. All MotorMaster Plus included manufacturers
2. Retrofit Electric Motors
  - 2.1. Toshiba and Teco motors only
  - 2.2. All MotorMaster Plus included manufacturers

The results and differences were quite dramatic:

**Table: Scenario Comparison (All values are "after tax")**

	<b>1.1</b>	<b>1.2</b>	<b>2.1</b>	<b>2.2</b>
<b>Capitol Costs</b>	\$65,470	\$21,643	\$70,381	\$61,673
<b>Savings (kWh/yr)</b>	388,930	450,049	261,778	350,665
<b>Net Present Value</b>	\$46,606	\$94,081	\$11,872	\$40,036
<b>ROI</b>	38%	315.4%	22.8%	36.2%
<b>Benefit:Cost</b>	1.71	5.35	1.17	1.65

Based upon the financial aspects of this analysis, the following recommendations would produce significant financial benefit:

- ❑ The opportunities identified through the analysis were based upon the efficiency benefits. While the initial cost had some impact, MM+ determines the top three efficiencies and lowest cost manufacturers for its analysis. It is recommended that the Toshiba and Teco product lines are reviewed from a first cost and reliability standpoint.
- ❑ A repair versus replace program should be put into place immediately. A significant finding in the analysis was that this type of program would yield immediate paybacks on most recommended electric motors.
- ❑ Variable torque loads, such as fans and pumps should be investigated for VFD application. For instance, one of the pump motors was found to vary in load (17% to 85% loaded), it was found to be an excellent candidate for a variable frequency drive. The benefits included the energy savings associated with the VFD plus the added benefit of reduced power factor costs.
- ❑ A motor system maintenance and management program should be initiated.

## Compressed Air System Opportunities

Compressed air is a necessary part of most plant operations, but is probably the most inefficient source of energy in a plant. To operate a one horsepower air motor, you need seven to eight horsepower of electrical power into the compressor. At higher than typical pressures, even more power is needed:

- ❑ 30 scfm @ 90 psig is required by the 1 hp air motor.
- ❑ 6-7 horsepower at compressor shaft is required for 30 scfm
- ❑ 7-8 horsepower is required for one horsepower at the shaft

The overall efficiency of a typical compressed air system can be as low as 10-15 percent. For instance, annual energy costs for a one horsepower air motor versus a one horsepower electric motor, 5-days per week, 2 shift operation, \$0.05/kWh: \$1,164 (compressed air) versus \$194 (electric).

Leaks can be a significant source of wasted energy in an industrial air system, sometimes wasting 20-30% of a compressor's output. A typical plant that has not been well maintained will likely have a leak rate equal to 20% of the total

compressed air production capacity. On the other hand, proactive leak detection and repair can reduce leaks to less than 10% of compressor output.

In addition to being a source of wasting energy, leaks can also contribute to other operating losses. Leaks cause a drop in system pressure, which can make air tools and other equipment function less efficiently, adversely affecting production. In addition, by forcing the equipment to cycle more frequently, leaks shorten the life of almost all system equipment, including the compressor package itself. Increased running time can also lead to additional maintenance requirements and increased unscheduled downtime. Finally, leaks lead to adding unnecessary compressor capacity.

Since air leaks are almost impossible to see, other means must be used to locate them. The best way to detect leaks is to use an ultrasonic acoustic detector, which can recognize the high frequency hissing sounds associated with air leaks. These portable units consist of directional microphones, amplifiers, and audio filters, and usually have either visual indicators or earphones to detect leaks. A simpler method is to apply soapy water with a paint brush to inspect areas. Although reliable, this method can be time consuming. Other methods include smoke sticks, candles, foam, manometers, and stethoscopes.

The issues with compressed air found at the miller are as follow (these do not represent all of the compressed air opportunities, just those in the areas studied):

- ❑ Air pressure drop from 110 psi to 45 psi in the packaging plant.
- ❑ Air leaks in the fungi and cooking plant.
- ❑ Open blow-off valve in one high pressure (150 psi) filter.
- ❑ Long lengths of flexible air hose and air hoses in poor condition.

#### Packaging Plant Pressure Drop

There were a number of issues identified within the compressed air system at the starch and gluten packaging plant. These issues included: an air pressure drop from 110 psi to 45 psi from the compressors to the end of the packaging line (measured at air regulators); the compressors do not have an opportunity to unload; compressed air is also used for bag houses; and the need for a compressed air strategy.

There are two 150 horsepower electric motors running in two Sullair air compressors located in the starch and gluten packaging plant. During the course of the study, these were monitored and found to operate at 90 kW for a Siemens motor (AC702) and 130 kW for a Lincoln motor (AC701). The Siemens motor

was found to be 73.8% loaded and the Lincoln 106.7% loaded. Both compressors remained online for the 48 hours of monitoring and the system was found not to unload. Total input power of the compressed air system was found to be 220 kW. Due to pressure drops and air demand, the present plan has been to install and additional air compressor.

Through a basic walk-through of the compressed air system, several areas were identified: a complete understanding of the demand side of the compressed air system is not really identifiable; the bag house air lines were not found and traced for air leaks; there was a significant pressure drop across the packaging line (100 psi to 45 psi). For the purpose of this area of study, the compressed air opportunities will focus on the packaging line with general recommendations for the remaining compressed air system.

The identification of challenges on the packaging line was through the identification in the pressure drop. A general walkdown of the packaging line identified a number of air leaks that could be felt and heard. The pressure drop had the following effect:

$$\begin{aligned} \text{Equation: System Air Pressure Drip} \\ P_{\text{pfl}} &= P_{\text{pfl}} * (100\% - 5\% * \text{pressure drop}) \\ &= 220 \text{ kW} * (0.5\% * 55 \text{ psi}) \\ &= 60.5 \text{ kW} \end{aligned}$$

Based upon a 0.05% change in demand for every psi, the power required to maintain the pressure drop is 60.5 kW (81 hp) which is 27.5% of the compressor load. This pressure drop was found to be a combination of the pneumatic controls for the packaging line and air leaks. A system for correcting the existing air leaks will go a long way to correcting the losses on the packaging line. For instance, one air leak at the end of the process was found on the upper level of the end of the packaging line on an air filter (right hand side at top of the stairs) and is estimated at a 3/8 inch leak. Other, smaller leaks have been identified within a number of air lines on the lower level at the end of the packaging line (these leaks were audible).

**Equation: CFM Loss from 3/8 Inch Air Leak**

$$V_f = \frac{NL * (T_1 + 460) * \frac{P_1}{P_i} * C_4 * C_5 * C_d * (\frac{pD^2}{4})}{C_6 * \sqrt{T_1 + 460}}$$

$$= \frac{1 * (90 + 460) * (\frac{50}{14.7}) * 28.37 * 60 * (\frac{3.146 * .375^2}{4})}{144 * \sqrt{80 + 460}}$$

$$= 105.25 \text{ CFM}$$

**Equation: Power Loss Conversion from CFM**

$$L = \frac{P_1 * C_6 * V_f * (k/k-1) * N * C_7 * [(P_0/P_1)^{\frac{k-1}{k*N}} - 1]}{E_a * E_m}$$

$$= 24.3 \text{ hp} * .746 \text{ kW/hp}$$

$$= 18.1 \text{ kW}$$

Therefore, in the case of the 3/8 inch leak, 18.1kW worth of energy is being wasted which has an overall cost of:

**Equation: Cost of 3/8 inch Air Leak**

$$\text{Annual Demand} = (4\text{mo's} * 18.1\text{kW} * \$12.70/\text{kW}) + (8\text{mo's} * 18.1\text{kW} * \$7.50/\text{kW})$$

$$= \$2,005.48$$

$$\text{Annual kWh cost} = 18.1\text{kW} * 6,000 \text{ hrs/yr} * \$0.037/\text{kWh}$$

$$= \$4,018.20$$

$$\text{Total} = \$6,023.68$$

**Table: Air Leak Formulae Definitions**

<u>Symbol</u>	<u>Definition</u>
V <sub>f</sub>	Volumetric flow rate of free air, cubic feet per minute (CFM)
NL	Number of air leaks, no units
T <sub>1</sub>	Temperature of the air at the compressor inlet, F
P <sub>1</sub>	Line pressure at leak in question, psi
P <sub>1</sub>	Inlet (atmospheric) pressure, 14.7 psi
C <sub>4</sub>	Isentropic sonic volumetric flow constant (28.37 ft/sec)
C <sub>5</sub>	Conversion constant, 60 sec/min
D	Leak diameter, inches
C <sub>6</sub>	Conversion constant, 144sqin/sqft
T <sub>1</sub>	Average line temperature
L	Power loss due to air leak, hp
K	Specific heat ratio of air, 1.4, no units
N	Number of stages, no units
C <sub>7</sub>	Conversion constant, 3.03 x 10 <sup>-5</sup> hp-min/ft-lb



P <sub>o</sub>	Compressor operating pressure, psi
E <sub>a</sub>	0.88 for single stage reciprocating compressors
E <sub>a</sub>	0.75 for multi-stage reciprocating compressors
E <sub>a</sub>	0.82 for rotary screw compressors
E <sub>a</sub>	0.72 for sliding vane compressors
E <sub>a</sub>	0.80 for single stage centrifugal compressors
E <sub>a</sub>	0.70 for multi-stage centrifugal compressors
E <sub>a</sub>	0.70 for turbo blowers
E <sub>a</sub>	0.62 for roots blowers
E <sub>m</sub>	Compressor motor efficiency, no units

While the \$6,023.68 air leak was not the only one, it was the largest in the packaging line. The total compressed air drop cost was \$20,191.98. Through a compressed air strategy on the packaging line both the pressure drop and high air leak costs can be reduced by at least \$15,000.00 with the remaining costs being found in the pneumatic controls and unfound air leaks. Payback on such a program would be (Replacement gaskets and valves, \$50; labor, based upon 8 hours per year at \$25/hr, \$400):  $(\$450/\$15,000)*12 \text{ mo.'s/year} = 0.36 \text{ month}$ .

Additional measures that may be taken before adding compressor capacity would include:

- ❑ Increase the capacity of the receiver. This would allow the compressors to load and unload (cycle) improving overall compressor system life.
- ❑ Balance the load on the two compressors. AC701 was 107% loaded and AC702 was 74% loaded. By balancing the load on the two compressors, the life of the motor and compressor components on AC701 will increase.

- Install surge tanks near the bag houses were served by the compressor system. This also reduced the load on the compressor system as well as improved the system line pressure. Without the surge tanks in place, air line pressure losses came into play based upon the air line size and distance, reducing the effectiveness and pressure of air to the baghouses.

#### Air Leaks at the Fungi and Cooking Plant

During the survey of the fungi and cooking plants, it was determined that there were two minor and one major air leaks within the compressed air system. The major air leak will be reviewed second, with two minor leaks as follow.

The first air leak was identified at the bottom end of one of the fungi tanks and represented a 0.25 inch opening. Using the air leak formulae, this leak put out 140.33 cfm resulting in a 30kW demand. The resulting cost for this leak was \$13,046.40 per year.

The second air leak was located at an air filter located at the rear of the fungi tanks on the second floor. The air leak may have been related to blowing off vapor and other contaminants trapped by the filter. The estimated leak is the same as the first air leak (0.25 inches) and resulted in an identical calculation of

140.33 cfm and \$13,046.40. The resolution to this air leak was to close the blow-off valve.

Throughout the course of the five week study at the miller, it was difficult to enter the area immediately below and near the fungi tanks due to noise. During the second phase study the cause of the noise was identified and determined to be a large separator following a heat exchanger and before the dryer on the high pressure air line.

Based upon the size of the piping, the amount of air, and the position of the blow-off valve, this opening was conservatively determined to be 0.5 inches at 150 PSI. Based upon the cfm and energy formulae, 561 cfm was being lost, accounting for 120 kW demand (160 hp) lost due to the open valve. The total cost for the open valve was \$52,185.60 per year.

The recommendation for this opportunity is to determine and correct for the cause of keeping the blow-off valve open, then close the valve. The payback for this opportunity was immediate.

### Additional Recommendations

Throughout the course of the study additional leaks and opportunities were identified. Following is a list of additional recommendations for improving the compressed air system at the miller.

- Reduce long lengths of flexible compressed air hose. Such areas as the alcohol storage tanks, as well as a number of production areas, have long lengths of flexible compressed air hose. Pressure drops within hose will be significant and can be avoided through: running permanent air lines to equipment that requires compressed air; and, putting surge tanks near equipment that requires a great deal of compressed air in order to off-set additional line losses.
- Replace manual blow-off valves on compressed air filters and separators with automatic blow-off valves. This both reduces maintenance requirements and ensures that blow-off valves are not maintained in the open position.
- Establish a compressed air strategy to include a compressed air maintenance and inspection program.

A basic compressed air strategy consists of the following points:

- ❖ Storage requirements
  - Make sure that primary storage is adequate

- Consider strategic secondary storage for some applications (surge tanks)
- ❖ Appropriate uses
  - Evaluate each major class of compressed air end-use
  - Check end uses against inappropriate uses
- ❖ Controls
  - Periodically work with your equipment service provider to adjust individual compressor controls
  - For systems with multiple compressors, use controls to orchestrate the compressors (multiple compressor sequencing)
  - Consider flow controllers
- ❖ Leaks
  - Get the equipment necessary to find leaks
  - Start looking in the right places
  - Learn how to repair leaks
  - Establish a leak prevention program
- ❖ Maintenance
  - Follow the maintenance guidelines for the compressor
  - Follow the maintenance guidelines for your other compressed air system components
  - Develop a scheduled maintenance program

When reviewing potential compressed air opportunities:

- ❑ Develop then review a block diagram of the system
- ❑ Develop and review system pressure profiles. Remember the nameplate horsepower is not always the true power consumption. Pressure drops across

equipment (e.g. dryers) are important in developing loss and possible opportunities for improvement.

- Develop and review the demand flow profile. If possible flows should be measured, if not economically or physically feasible, use manufacturers equipment rating, or best estimate using compressor loading when the equipment is in service.

### Steam Opportunities

There were three basic opportunities with the steam system at the miller including steam traps, steam leaks, and waste steam.

#### Miller Steam System

Steam was purchased from the local utility co-generation plant located on the miller's property. During fiscal year 1995, the company negotiated a fifteen year agreement to purchase steam heat and electricity from a utility for its Illinois operations. Steam heat was being purchased for a minimum monthly charge of \$114,000, with a declining fixed charge for purchases in excess of the minimum usage. In connection with the agreement, the company leased land to the utility

company for 15 years so it could construct a co-generation plant at the company's Illinois facility.

From the co-generation plant 170 psi steam was provided for high pressure steam turbines, cookers, stills, and high pressure condensate return tanks. High pressure steam was provided at 225-290 thousand pounds per hour. The low pressure steam was provided following use by the high pressure steam turbines and the Hi/Low makeup. Low pressure steam was maintained between 15 to 20 psi at 130 to 190 pounds per hour and is provided for stills, evaporators, and other systems.

#### Steam Trap Opportunities

When it comes to steam traps, plants often ignore them. Complacency about them costs steam users more than they realize. Losses from wasted energy, damaged equipment, misused personnel hours, or poor product quality can be in the hundred of thousands of dollars.

There were a total of 37 steam traps of which three were blowing through, two leaked, and two were cold plugged. This represented a failure rate of 18.9%. In addition, there were three locations which required steam traps that do not have

them. Total cost due to defective steam traps was \$7,546 in direct steam costs. This cost does not include any maintenance requirements due to condensate moving in the steam system, particularly with the steam traps that were cold plugged.

**Table: Failed Steam Traps**

<b>Tag Number</b>	<b>Condition</b>	<b>Loss (klb/yr)</b>	<b>Cost (\$/yr)</b>
Distillation HP Drip	Blow Through	986	\$3,942
Distillation LP Drip	Blow Through	14	\$56
611 LP Drip	Blow Through	336	\$1,345
634	Leak	58	\$232
661 Dryer Turbine	Cold Plugged	0	\$0
661 Dryer Turbine	Cold Plugged	0	\$0
HP Drip South Wall	Leak	493	\$1,971
351 HP Drip	Valved Off	0	\$0
351 LP Drip	Valved Off	0	\$0
HX564	Missing	0	\$0
<b>Total</b>		<b>1887</b>	<b>\$7,546</b>

Recommendations for steam traps at this plant were:

- Repair or replace the malfunctioning traps for an immediate payback.
- Implement an in-house testing and maintenance program.
- Increase attention to proper sizing of steam traps for all new installations.
- Install test valves or sight glasses in steam lines for visual trap testing.



Steam Leak Opportunities

Throughout the fungi and cooking plants a number of leaks were observed. The difference between steam leaks and waste steam is that steam leaks were identified as bad gaskets and valves in the steam lines, while waste steam was identified as deliberate steam exhaust through valves or other orifices.

The following tables identify the costs for various steam leaks:

**Table: Steam Leaks, 170 psi, \$4/klb**

<b>Leak Size, Inches</b>	<b>Steam, CFM</b>	<b>Steam, lbs/hr</b>	<b>Hours operation</b>	<b>Klbs/yr</b>	<b>\$/yr</b>
0.25	103	6	8760	54	\$215
0.5	410	25	8760	216	\$862
0.625	641	38	8760	337	\$1,348
0.75	923	55	8760	485	\$1,941
1	1642	98	8760	863	\$3,451
1.25	2565	154	8760	1348	\$5,392
1.5	3694	222	8760	1941	\$7,765
2	6566	394	8760	3451	\$13,805
2.5	10260	616	8760	5393	\$21,571
3	14774	886	8760	7765	\$31,062
4	26266	1576	8760	13805	\$55,221
5	41040	2462	8760	21571	\$86,282
18	531877	31913	8760	279554	\$1,118,218

**Table: Steam Leaks, 20 psi, \$4/klb**

<b>Leak Size, Inches</b>	<b>Steam, CFM</b>	<b>Steam, lbs/hr</b>	<b>Hours operation</b>	<b>Klbs/yr</b>	<b>\$/yr</b>
0.25	17	1	8760	9	\$35
0.5	66	4	8760	35	\$139
1	265	16	8760	139	\$557
2	1060	64	8760	557	\$2,228
3	2385	143	8760	1253	\$5,013
4	4239	254	8760	2228	\$8,913
5	6624	397	8760	3482	\$13,926
6	9538	572	8760	5013	\$20,053
7	12983	779	8760	6824	\$27,295
8	16957	1017	8760	8913	\$35,651

10	26495	1590	8760	13926	\$55,704
12	38153	2289	8760	20053	\$80,214
18	85845	5151	8760	45120	\$180,481

The above tables were based upon 170 and 20 psi steam as identified for the plant and \$4 per kilo-pound of steam.

Through the survey, a number of steam leaks were identified. Based upon the condition of the equipment and area around the leaks, as well as the fact that a number of the leaks existed during the entire audit period, there remains a number of opportunities in steam energy.

Total steam leaks at the fungi and cooking plant cost a total of \$33,430 per year in lost steam energy:

**Table: Steam Leaks**

<b>Location</b>	<b>Pressure, psi</b>	<b>Annual Cost</b>
First level by fungi tanks	20	\$140
Outside, second level near fungi tanks	170	\$31,060
Second level cooking area	20	\$2,230
<b>Total</b>		<b>\$33,430</b>

Recommendations included the following:

- Include a steam valve maintenance program and replace gaskets upon failure
- Replace and repair the present steam leaks for an immediate payback

## Plant Wide Lighting Retrofit Assessment

Lighting at the company made up an average demand of 300 kW. Based upon the phase one survey, a total reduction of 35kW is possible with an investment of \$80,600 for a 1.7 year simple payback. This amounted to a reduction in kWh of 1,203,100 per year. Combined total annual savings will be \$48,386 per year resulting in an after tax benefit to cost ratio of 27.4:1.

The primary retrofit opportunity includes the replacement of older T12 fluorescent lamps with new T8 lamp fixtures and electronic ballasts. Also, included in the retrofit recommendations are all found incandescent fixtures. The high intensity discharge lighting fixtures that do exist at the company were found to be appropriate for the application and are not recommended for retrofit.

## Miller Waste Stream

Observations of waste stream issues were observed during both phases of the miller study. These observations included:

- Excess product located on the ground from unloading through finished product.

- ❑ Water hoses placed on pumps with a constant stream running over the outside of the pump seal housings.
- ❑ Waste product from leaky pumps.
- ❑ Incorrect pressure settings on pump seal cooling water.
- ❑ Waste water
- ❑ Waste live steam.

#### Waste Water through Water Hoses on Pumps

Through both the first and second phases of the milling project, an observation was made concerning the use of water hoses on pumps to pour water over the pump seal housings. When maintenance was questioned concerning this practice it was explained that the operators place the hoses on the pumps. It was determined that there was a general perception that when the seals began to fail on the pumps that air was drawn into the product. This was carried further by the concept that pouring water over the leaks would prevent air from entering product. Maintenance informed UIC-ERC that they remove the hoses whenever they are discovered.

This perception was, of course, incorrect. When a pump seal failed, air was not drawn in. In general, the area behind the impeller has a higher pressure than the outside air pressure resulting in product being ejected through the seal leak to the outside, and not the other way around. Pouring water over the seal housing only increased the losses and dangers that occurred due to the leaking product ending

up on the floor. Assuming a water flow of 0.2 gpm, there was a general loss of 12 gallons per hour for each hose. This water is then run through the drain system and then into the evaporators. Overall losses per gallon included waste water costs, water costs, and evaporator costs. While the resulting costs are low (\$1/hour per hose) there is an immediate payback by just not using them as well as a reduced safety hazard by not adding to the floor, creating a tripping hazard, as well as adding water to the immediate area around electrical equipment. The resulting water also caused the base, motor, and other metal around the pump to rust and wear.

#### Excess Steam Recovery

Throughout the study waste steam was identified. This steam was found being vented from a waste steam stack on the fungi plant and through smaller steam pipes mounted over condensate returns. Methods of waste heat (steam) recovery should be investigated in order to reduce the overall cost of waste steam per year.

A conservative loss estimation for the exhaust of excess steam through the stack located at the fungi plant would be \$180,480 per year (45,120 klb/yr). These values are calculated as saturated steam flowing through an opening (20 psi for all waste steam).

**Table: Waste Steam Losses, Fungi Plant**

<b>Location</b>	<b>Losses (klb/yr)</b>	<b>Annual Cost (\$/yr)</b>
Fungi plant excess steam stack	45,120	\$180,480
Mash processing tanks (next to fungi tanks)	70	\$280
Near pumps next to lower level MCC	280	\$1,114
Fungi tanks turbine compressor	560	\$2,228
Fungi tanks	560	\$2,228
<b>Total</b>	<b>46,590</b>	<b>\$186,360</b>

There are several options for reducing waste steam, each of which would require additional study prior to implementation:

- ❑ Replacing electric motors with additional steam turbines
- ❑ Reducing the amount of steam provided to the plant
- ❑ Recompressing steam for re-use by the system
- ❑ Utilizing waste steam for refrigeration / air conditioning

Replacing Electric Motors With Additional Steam Turbines

It can be assumed that the reason for the waste steam had to do with the high pressure steam requirements for the turbine driven equipment. The wasted steam was released from the fungi plant excess steam and resulted in a steam plume greater than 50 ft from the top of the stack. On the secondary side of the steam system (20 psi), the wasted steam appears to come primarily from open piping leading to condensate traps. The issue on this side appeared to be that a majority of the vapor leaving the piping above the condensate traps was lost to the atmosphere.

Replacing electric motors with steam turbines would make an excellent option for reducing the amount of waste steam exhausted by the plant. The scope of the study did not allow for the direct selection of which electric motors would make candidates for this type of retrofit, nor on the associated costs. However, based upon the cost of steam at the miller and the cost of wasted steam, this would make an excellent option for further study.

#### Reducing the Amount of Steam Provided to the Plant

The least cost approach would be to simply reduce the amount of steam being provided to the plant. If production is not adversely impacted, simply reducing the amount of steam provided to the plant would have an immediate payback (100% savings). Production / operations personnel at the miller would have to weigh the option of the waste reduction measure before implementing to ensure that production had a minimal impact.

#### Additional Waste Stream Comments

In general, the miller utilized major waste products in an efficient manner. For instance, the major end products from all processes included waste high protein corn and carbon dioxide. The miller processed the corn as a high protein feed that

was sold and also sold the carbon dioxide to one of two plants located nearby. Those plants compressed the carbon dioxide then sold it.

Other opportunities, including waste steam, primarily were the result of process and maintenance issues. For instance: product lost through leaking pump seals; leaking pipes; waste corn on the ground; waste starch and gluten in the packaging area; burnt high protein corn from the dryers; waste low pressure steam; bad steam valves and gaskets; etc. Most of the issues are due to the age of the equipment while others can be connected through basic measures.

#### Maintenance and Reliability Observations

A number of maintenance and reliability opportunities presented themselves over the course of the audit. These included the following:

- Continue efforts in Predictive Maintenance program – Continue efforts in the development of the vibration analysis program. Improve efforts having to do with the infrared analysis program.
- Establish a motor maintenance and management system – As cited in the energy conservation chapter of this report, motor system energy accounts for over 98 percent of the electrical use of the plant and 3% of the overall energy



consumption of the miller. Such a program would include preventive, predictive, proactive, and corrective maintenance strategies.

- Take a proactive approach to seal failures – A study of the cause of failure of pump seals indicate incorrect application of the present seals in many of the Peerless pumps located throughout the fungi, cooking, and drying plants.

#### Vibration Analysis Program Continuous Improvement

The miller has implemented a vibration analysis program which is a vital element of any Predictive Maintenance program that includes rotating equipment. The primary cause of failure of any rotating equipment, including electric motors, is bearing failure (over 40%). Additional failure types that can be detected with vibration analysis include, but were not limited to:

- Early detection of bearing failure and tracking
- Shaft misalignment
- Sheave and belt misalignment and mis-tensioning
- Soft foot
- Loose and broken rotor bars
- Electrical phase unbalance
- Pump cavitation
- Loose or worn shafts

Vibration analysis is used in the following instances:

- ❑ Purchase and acceptance of new equipment.
- ❑ As part of a scheduled maintenance program to track equipment failure. The objective is to maximize the useful life of rotating equipment and to schedule equipment corrective maintenance versus catastrophic failure. In this way, repair is less expensive and there is less chance for production interrupting failures.
- ❑ To qualify repairs including bearings, alignments, and belt placement.
- ❑ Troubleshooting and root-cause analysis.

Continuing the program would include:

- ❑ Expand coverage of the equipment presently scheduled as part of the PdM program.
- ❑ Utilize vibration analysis for new equipment and repair acceptance.
- ❑ Root cause analysis of equipment failure.

#### Infrared Analysis

The purpose of infrared analysis is to detect variations in temperature between the ambient temperature and equipment components. For example, loose electrical contacts create high resistance points. These high resistance points generate heat which can be detected with infrared analysis. Infrared can detect:

- ❑ Loose electrical connections
- ❑ Bad contacts

- ❑ Glazed contacts and fuse clips
- ❑ Other high temperature points in electrical equipment
- ❑ Steam leaks
- ❑ Hot bearings

As all alternating current systems are subject to twice line frequency vibration (120 Hz in 60 Hz systems) some looseness due to vibration can occur in joints and connections. Common areas for conducting infrared analysis include:

- ❑ Motor Control Centers (MCC's)
- ❑ Buss work
- ❑ Motor starters, disconnects
- ❑ Other electrical panels

The miller was having infrared analysis performed by their insurance company and the utility.

During the survey, UIC-ERC had the opportunity to observe a number of MCC's while setting up data collection equipment:

- ❑ Have company electricians assist with the infrared analysis and make notes concerning other problems within the MCC buckets. For example, in the

- MCC on the lower level of the cooking plant one set of fuses was completely mis-matched which endangered the operating equipment and electrical circuit.
- As part of a preventive maintenance program, the MCC buckets needed to be cleaned. Disconnect and lockout/tagout the MCC center and vacuum out the bucket. The older MCC's were found to have a large amount of dust and cobwebs. This situation could cause equipment failure or fire.

#### Pump Seal Failure Analysis

The single most significant observable reliability issue at the miller was leaking pump seals throughout the fungi, cooking, drying, and distillery plants. This issue was observed in all but a few product pumps located on the lower levels of each building and amongst the tank farms.

The general perception of the cause of failure run two-fold: running product dry; running Sodium Hydroxide (pH of 14) through the pumps for cleaning. The result of the pump leaks also run two-fold; lost product, including the resulting energy and the energy necessary to dispose of the lost product; and, safety issues dealing with product covering walk areas.

Based upon the findings of the study on the pump seals, a number of issues were identified:

- Primarily, the wrong seals are being applied. The application, with between 5 to 10 percent solids actually calls for double seals, as opposed to the single seals used.
- Cooling waster needed to be applied. In all cases, constant cooling was required to each seal, including a constant water pressure within the seal.
- Low levels of material in tanks may cause cavitation. Cavitation resulted in seal chattering which ended with cracked and broken seals.

Other issues existed, more than likely, that would effect pump and seal life. However, in this application, the issues should dramatically increase pump seal life.

#### Pump Seal General Discussion

The miller had used outside repair centers and contractors repair the pump seals on each of the pumps, as required. Later the seals were replaced on-site, which included a retrofit to cartridge seals. The newer cartridge seals are fairly easy to use as they are inserted into the seal housing as a unit.

The cartridge seals cost \$605 brand new and \$363 to rebuild. The cartridge seals take approximately four to five hours to replace, including realigning the pumps. Through the course of the second phase of the project, over 18 leaking pump seals were identified during a one hour period. Assuming \$25 per man-hour, the cost to replace these seals would have been \$2,250 in labor plus \$10,890 for materials (\$13,140). From interviews with maintenance and operating personnel, the seals are lasting no longer than six weeks before the pumps were leaking again. Therefore, over the course of one year, the cost would have been \$114,000 to just replace the seals.

A second issue identified during the walk-through was only that a few pumps had fresh water supplied to the seal. In addition, the water was not controlled in any special fashion both wasting water and possible providing too high a pressure on the seal, which can contribute to early seal failure.

All of the product pumps move Sodium Hydroxide (pH 14) and other solvents which can damage most seal materials. As the Sodium Hydroxide is heavily diluted, and the materials selected are able to stand high pH, it is generally felt that, while this had contributed to seal failure, it was not the major cause.

One other area that was a problem, however, was the case of operating the pumps dry. While it was generally felt that this was a training issue with the operators, there were other methods to safeguard the equipment. During the course of the study, it was noticed that the equipment and Programmable Logic Controllers (PLC's) are being installed to control and monitor production. Through the use of flow, pressure, and level sensors, the PLC's can be used to prevent pumps from operating without fluid present.

#### Identification of Failure Mode

During the course of the second phase of the study, several failed pump seals were provided for analysis. When evaluating these seals, it became obvious that the seals failed from a combination of heat, scoring, and vibration. These were due to a lack of lubrication, particulate in the materials being pumped, and cavitation. In addition, it was determined that some material had been escaping past the o-ring and shaft sleeve. This was, more than likely, due to wear on the shaft from the previous seal. The following recommendations applied:

- Convert all seals to double seals to withstand the amount of particulate in the fluid being pumped.

- While bringing in fresh water to provide cooling and lubrication to the seals, also ensure that the pressure is set correctly for the seal housing.
- Add in flow, pressure, or level metering, as appropriate, to prevent pump cavitation due to low product levels.

#### Pump Seal Savings

The application of double seals had the potential of improving the life of the seal from less than six weeks to more than one year. The double seals for the application cost \$1,291 each, with the same amount of labor required for application as the single seal. On the 18 pumps identified in the second phase of the study, an annual reduction of, conservatively, \$88,512 (\$114,000 annual single seal cost - \$23,238 for 18 seals - \$2,250 internal labor) which yields a 3 month simple payback. It is highly recommended that a pump seal supplier is contacted to advise on the selection and application of the double seals.



## Additional Reliability Recommendations

A number of basic observations were made during the course of the first and second phase of the project. These observations were based upon the experience of ERC personnel experience in similar plants:

- Schedule regular walk throughs of the plant observing: air and steam leaks; electrical problems; leaking pumps; etc.
- Continue development and implementation of vibration analysis programs.
- Increase effectiveness of infrared analysis by observing physical conditions of equipment versus just hot spots. Ensure that the infrared technician, or a helper, is opening cabinetry to allow for a direct view of the equipment being analyzed. Infrared analysis does not work through walls or cabinets.
- Keep floor areas clean of spills due to materials and pump leaks.
- Coordinate maintenance efforts: while investigating the leaky seals, the parts purchasing manager passed on some observations concerning how and why certain parts were ordered and stocked. Apparently, a number of other pieces of equipment fail on a regular basis. By including this part of the maintenance system in the reliability loop, troubled equipment can be identified for root cause analysis. Parts stock and the reliability group were located in the same building.

## Chapter 5: Conclusions

Standard industrial energy audits have inherent problems. First of all, they are often performed by engineers with limited real experience, or experience in the industry being audited. Secondly, the audit is primarily concerned with reducing energy or waste from the process with limited, or no, concern for the impact on the process, equipment reliability, or product quality. The goal is mainly a dollar value reduction in overall energy costs versus a reduced cost per unit of production or improved corporate competitiveness. As a result, the overall system is often overlooked.

In order to properly perform an audit that would be of greatest benefit to an industrial or commercial user, a complete assessment must be performed. As part of this assessment, simulation software should be used to handle the complexities of the opportunities and their impacts. The simulation package may be as simple as a spreadsheet or MotorMaster Plus to a full ProModel production simulation.

The industrial assessment itself should be broken down into opportunities which review at least: 1) Energy opportunities; 2) Waste stream opportunities; 3)

Process and production; and, 4) Reliability. However, the method for approach should vary by type of industry and the company itself:

1. Determine the scope of the industrial assessment. Utilize outside sources with experience within the industry, as appropriate. This should include a walkthrough looking for obvious opportunities.
  - 1.1. Look for employees waiting for production flow or for employees attempting to "look busy." In these cases, there is often opportunities for increasing production flow.
  - 1.2. When entering the facility watch for the following:
    - 1.2.1. Inefficient lighting, offices and work areas that appear too bright, large, empty spaces that are lit.
    - 1.2.2. Spaces too cool for the type of production being performed.
    - 1.2.3. Compressed air noise.
    - 1.2.4. Waste excess steam and steam leaks.
  - 1.3. While walking through the plant, watch for the following:
    - 1.3.1. Equipment operating without product flow.
    - 1.3.2. Broken equipment or large amounts of equipment standing by for repair.
    - 1.3.3. Large stock of spare equipment, especially if the spares are spread throughout the plant and not organized in one area.

- 1.3.4. Large amounts of inventory coming in and/or leaving.
- 1.4. Get ahold of at least one, preferably two, years of data for electricity, gas/oil, co-generation, waste water, waste materials, disposed waste, recycled waste, production volume, incoming versus outgoing weights, and other information, as necessary.
2. Gather all information and assess the areas which will require attention. These will often be the greatest opportunities.
3. Select personnel or outside surveyors for performing the assessment. Ensure that backgrounds vary to provide the best review of opportunities in each area.
  - 3.1. Prepare and plan the type of simulations to be performed to ensure that the correct information is gathered.
  - 3.2. Review potential opportunities and production alternatives. This could include the utilization of fuel cells versus gas turbine co-generation.
  - 3.3. Gather data including energy, time studies, equipment nameplates, floor plans, etc.
4. Assess all data and review potential improvements and interaction amongst the opportunities:
  - 4.1. Set up and perform simulations. Review multiple options such as the impact on production through the use of variable frequency drives versus constant speed drives, etc.

- 4.2. Select the best options and determine the energy, waste stream, process, and reliability opportunities and payback.
5. Develop a report and presentation with the following outline:
  - 5.1. Cover page
  - 5.2. Executive summary, use graphs and charts as necessary to establish points
  - 5.3. Table of Contents
  - 5.4. Table of figures and table of formulae
  - 5.5. Energy, waste stream, and production information, preferably broken down by unit of production.
  - 5.6. Energy opportunities, include formulae to support recommendations, and write details in a simple, straight-forward manner.
  - 5.7. Waste Stream opportunities
  - 5.8. Production opportunities
  - 5.9. Reliability considerations
  - 5.10. Summary of the interaction between each set of recommendations
  - 5.11. Attachments including the following:
    - 5.11.1. Provided information
    - 5.11.2. Simulation results
    - 5.11.3. List of equipment
    - 5.11.4. Floor plans

#### 5.11.5. Other data as required.

Such a program can improve industrial competitiveness by at least 15 to 20%, for process-heavy industries.

## Bibliography

- Berry, L. Douglas (1994). Assuring Mechanical Integrity of Electric Motors. Branchville, SC.
- Bodine Electric Company (1993). Small Motor, Gearmotor and Control Handbook. Chicago, IL.
- Briggo, Bartos, and Arno (1998). “Reliability and Availability Assessment of Electrical and Mechanical Systems” IEEE Transactions on Industrial Applications. November/ December 1998, Piscataway, NY. Pp 1387-1396.
- Burres, Keith, Rogers, Charles (1998). “The Reliability Balanced Scorecard” Maintenance Technology (December 1998), Barrington, IL. p.21
- Demand Side Energy Consultants, Inc. (1995). Evaluation of Electric Motor Repair Procedures. LTEE, Vancouver, BC.
- Dunn, Ray (1998). “Measuring the Cost of Unreliability” Maintenance Technology (October 1998). Barrington, IL p. 25.
- Hubert, Charles (1969). Preventive Maintenance of Electric Equipment. McGraw-Hill, New York, NY.
- Ingersoll-Rand (1998). Torrington Service Catalog. Torrington, CN.
- Institute of Electrical and Electronics Engineers, Inc. (1999). IEEE Industry Applications Magazine (April, 1999). Piscataway, NY.

- Koval, Don O and Floyd, H. Landis (1998). “Human Element Factors Affecting Reliability and Safety” IEEE Transactions on Industry Applications. March/ April 1998. Piscataway, NY. Pp. 406-414.
- MRC Bearings (1998). MRC Engineering Handbook. Jamestown, NY.
- Nailen, Richard L. (1996). “What’s the Best Way to Reduce Bearing Friction” Electrical Apparatus. June 1996. Chicago, IL. P. 38-41
- Nailen, Richard L. (1994). “How Important is Friction and Windage Loss?” Electrical Apparatus. December, 1994. Pp. 29-39.
- Penrose, Howard W. (1998). A Novel Approach to Electric Motor System Maintenance and Management for Improved Industrial and Commercial Uptime and Energy Costs. Aurora, IL. Kennedy-Western University.
- Penrose, Howard W. (1996). “Field Testing Existing Electric Motor Insulation for Inverter Duty” Electrical Manufacturing and Coil Winding 1996. Pp 109-114.
- Penrose, Howard W. (1997). Repair Specification for Low Voltage Polyphase Induction Motors Intended for PWM Inverter Application. Aurora, IL. Kennedy-Western University.
- Penrose, Howard W. and Dreisilker, Leo F. (1998) “The Mechanical Effects of Thermal Stripping on Electric Motor Stators” Electrical Manufacturing and Coil Winding 1998.



- Rockwell Automation (1998). Dodge Power Transmission Components Engineering Catalog. Greenville, SC.
- Rutgers University (1996). A Self-Assessment Workbook for Small Manufacturers. State University of New Jersey Industrial Assessment Center.
- Rutgers University (1996). Industrial Productivity Training Manual. State University of New Jersey Industrial Assessment Center.
- Rutgers University (1996). Modern Industrial Assessments: A Training Manual. State University of New Jersey Industrial Assessment Center.
- Shear, Mel A. (1983). Handbook of Building Maintenance Management. Reston Publishing, Reston, VA.
- Siemens (1997). Step 2000, AC Motors. Alharetta, GA.
- Siemens (1997). Step 2000, AC Drives. Alharetta, GA.
- Siemens (1997). Step 2000, Basics of Control Components. Alharetta, GA.
- Siemens (1997). Step 2000, Basics of PLC's. Alharetta, GA.
- Siemens (1997). Step 2000, Enclosed Switches. Alharetta, GA.
- Siemens (1997). Step 2000, Molded Case Circuit Breakers. Alharetta, GA.
- Siemens (1997). Step 2000, Busway. Alharetta, GA.
- Siemens (1997). Step 2000, Panelboards. Alharetta, GA.
- Siemens (1997). Step 2000, Switchboards. Alharetta, GA.
- Siemens (1997). Step 2000, Load Centers. Alharetta, GA.
- SKF (1998). SKF Ground Catalog. SKF, USA.

- US Department of Energy (1996). Energy Efficient Electric Motor Selection Handbook. Bonneville Power Administration.
- US Department of Energy (1996). Energy Management for Motor Driven Systems. Bonneville Power Administration.